

Smappee EV Ultra Dual Installation manual



Document accuracy

The specifications and other information in this document were verified to be accurate and complete at the time of its publication. Due to ongoing product improvement, this information is subject to change at any time without prior notice. For the latest information, see our online documentation: smappee.com/downloads

Table of contents

1. Introduction.....	4
2. Safety instructions.....	5
3. Overview of the EV Ultra.....	6
4. Preparing the installation.....	12
5. Installation and configuration	20
6. Maintenance.....	30
Annexes	32

1. Introduction

Thank you for purchasing this Smappee EV Ultra charging station for electric vehicles, the smartest DC charging station for businesses.

This installation and user manual tells you how to install and use the Smappee EV Ultra. We recommend that you read the contents of this manual carefully, to ensure a safe and proper installation and enable you to use all the advanced features of this product to the full.

Support

Only qualified electricians or equivalent may install the Smappee EV Ultra. If you have any questions, please contact your service partner.

Please have the following information ready to hand to speed up the process: Article number and serial number which you can find on the identification label of the EV Ultra.



Should your local distributor be unable to help you, or you have a suggestion for us, you can contact Smappee at: support@smappee.com.

Smappee NV
Evolis 104
8530 Harelbeke
Belgium

2. Safety instructions

2.1. Safety warning

Fully read and follow the safety instructions below before you install, service or use your Smappee EV Ultra. The installer must ensure that the charging station is installed in accordance with the relevant national and local regulations.

Carrying out activities on this charging station without the relevant knowledge and qualifications can lead to serious accidents and death. Only carry out tasks for which you are qualified and have been fully instructed.

Incorrect installation, repairs or modifications can result in danger to the user and may void the warranty and liability.

2.2. Safety precautions

	<p>CAUTION</p> <p>Risk of electric shock.</p> <p>Refer to the accompanying documentation whenever you see this symbol.</p>
---	---

Please observe the following safety precautions to avoid potential electric shock, fire, or personal injury:

- The charging station is intended exclusively for charging electric vehicles and, when installed correctly, may be used by untrained individuals.
- Switch off electrical power supply to your charging station before installation or maintenance work.
- Do not use the charging station if damaged / defective.
- Do not immerse the charging station in water or any other liquids.
- Do not expose the charging station to heat, flame or extreme cold.
- Do not attempt to open, repair, or service any parts. Contact Smappee or your service partner for further information.
- Only use the charging station under the specified operating conditions.
- Do not allow children to operate a charging station.
- When a charging station is in use, adult supervision of any children present is required.
- While charging the charging cable must be completely unwound and connected to the electric vehicle without overlapping loops. This to avoid the risk of overheating the charging cable.

2.3. Keeping order

- After charging, store the charging cable properly so it does not present a tripping hazard.
- Make sure the charging cable cannot become damaged (kinked, compressed or driven over).
- Do not place any objects on the charging station.

3. Overview of the EV Ultra

3.1. Models

Charging stations

Article no.	EAN	Description
EVU-80D-C3-W	5425036934955	EV Ultra Black, Standalone, 2 connectors, 40kW per connector
EVU-80D-C3-B	5425036934368	EV Ultra White, Standalone, 2 connectors, 40kW per connector
EVU-240D-C3-B	5425036934382	EV Ultra Black, Standalone, 2 connectors, 120kW per connector
EVU-240D-C3-W	5425036934986	EV Ultra White, Standalone, 2 connectors, 120kW per connector

Anchor (to be ordered separately)

Article no.	EAN	Description
EVU-ANCHOR	5425036934450	EV Ultra mounting anchor

3.2. Directional determination

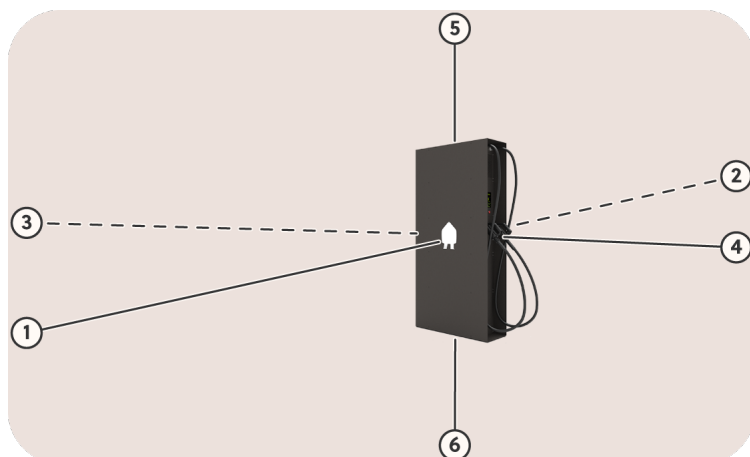

Image 1: Directional determination

Id	Description
1	Front
2	Rear
3	Left
4	Right
5	Top
6	Bottom

3.3. Identification label

Position of the identification label of the EV Ultra

The identification label of the charging station is located above the connector.



Image 2: Position of the identification label

Content of the identification of the EV Ultra

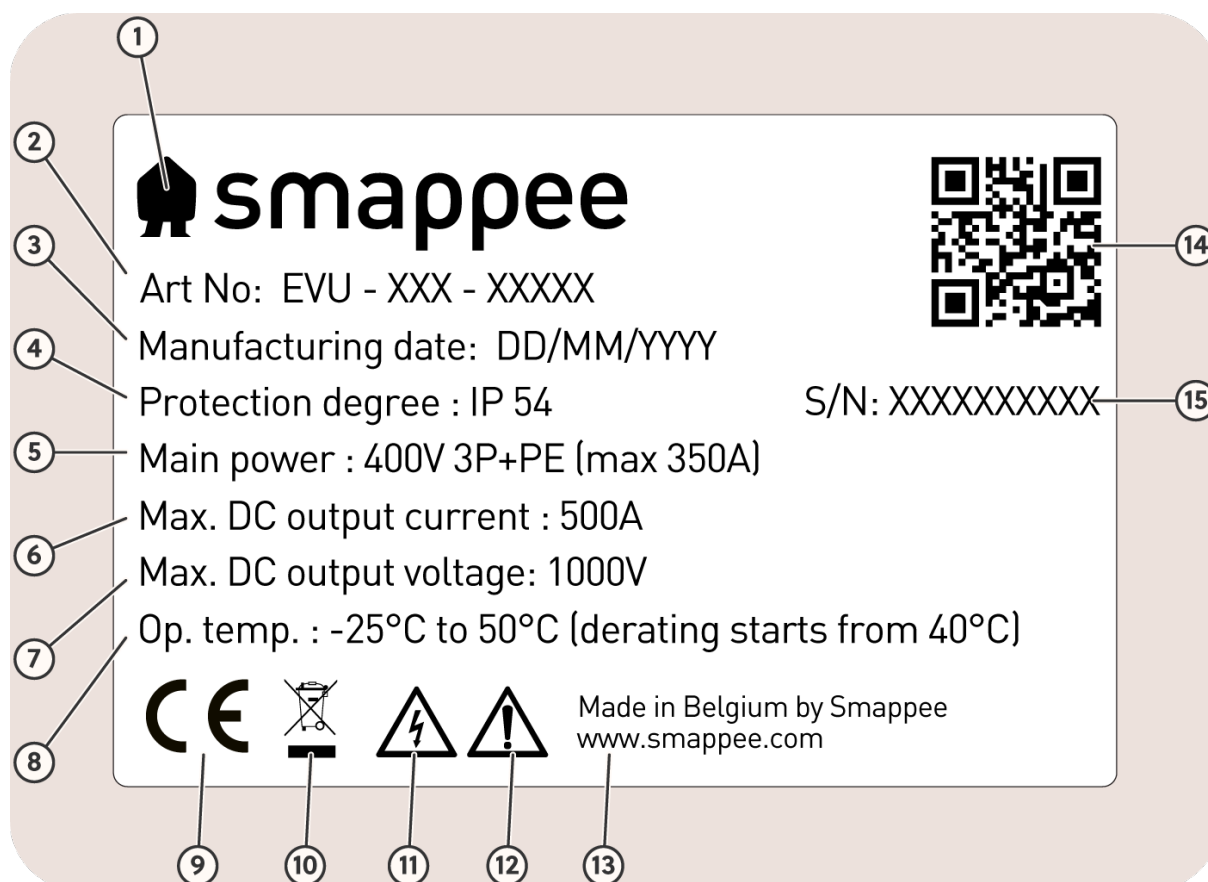

Image 3: Identification label

No.	Description
1	Manufacturer's logo
2	Article number
3	Manufacturing date
4	IP rating
5	Electrical rating
6	Maximum DC output current
7	Maximum DC output voltage
8	Operating temperature
9	CE
10	Waste disposal symbol
11	Electric hazard symbol
12	Warning symbol
13	Manufacturer's data
14	QR code to scan during configuration of the charging station
15	Serial number

3.4. Technical specifications

Feature	Description
Physical properties	
Dimensions	1870 x 920 x 325 mm
Charging unit weight (excluding packaging)	EV Ultra 40D: 240 kg EV Ultra 120D: 340 kg
Anchor	23 kg
Charging cable length	3.25 m
Stationary / moveable	Fixed installation
External design	Enclosed assembly
Mounting method	Ground mounted, with supplied anchor
AC input	
Power supply	3P + PE
Auxiliary power supply	5G2.5 mm ²
Rated voltage (U _N)	400 Vac ± 10 %
Rated frequency (f _N)	50 Hz
Nominal input current	EV Ultra 40D: 120 A EV Ultra 120D: 350 A
Power factor	> 0.98 at full capacity
Efficiency	95% at full capacity
Connection method	AC, permanently connected
Integrated protective measures	Galvanically isolated inverters
DC output	
Charge mode	Mode 4 (IEC 61851)
DC Plug	CCS2
Connection case	Case C (fixed cable) (IEC 61851)
Maximum current	500 A (boost mode)
Voltage	100 V – 1000 V
Nominal power charging point	EV Ultra 40D: maximum 40 kW EV Ultra 120D: maximum 120 kW
Nominal power charging station	EV Ultra 40D: maximum 80 kW EV Ultra 120D: maximum 240 kW

Feature	Description
Interfaces & Connectivity	
Information status	6.5" RGB Display
Session activation	QR code / RFID (Optional payment terminal)
Connectivity	Ethernet 100BASE-T LTE Cat M1 (4G)
Communication protocol	OCPP 1.6 J, ready for update to OCPP 2.0.1
Metering	kWh meter compliant with IEC 62053-21
Certifications and Standards	
Product certification	CE
Standards	IEC 61851-21, ISO 15118, DIN SPEC 70121
Environment	
Enclosure material	Powder coated steel
Enclosure standard colours	RAL 9016 (star white) + RAL 7021 (black grey) Optional customisation
IP rating	IP 54
Mechanical impact protection	IK 10
Pollution degree	3
Electrical safety class	I
Stand-by use	150 W
Acoustic noise	0 dB to 60 dB
Environmental conditions	Indoor and outdoor use
Operating temperature	-25 °C to 50 °C (power derating from 40 °C)
Storage temperature	-25 °C to 70 °C
Relative humidity	0 % to 95 %, non-condensing
Operating altitude	0 to 2.000 m
Access	Locations with restricted and non-restricted access



NOTE

The operating temperature assumes the ambient temperature of a product delivered in the default enclosure colours RAL 9016 (star white) or RAL 7021 (black grey). Direct exposure to sunlight may have an adverse effect on the temperature range.



NOTE

If the product is exposed to lower or higher ambient temperatures, continuous operation cannot be guaranteed. If temperatures exceed the maximum values, the charging station will automatically decrease the charging current to decrease the internal temperature of the charging station.

This stabilises the internal temperature and makes it less likely that a transaction will be unexpectedly paused.



NOTE

If the product is directly exposed to sunlight, the automated temperature management may automatically start below the maximum ambient temperature. Therefore, wherever possible, avoid exposing the charging station to direct sunlight.



NOTE

Where products are exposed to the elements of nature, the enclosure can be subject to gradual aging of the material, which can result in product discolouration over time. Therefore, wherever possible, place the product in a sheltered place to optimise the life of the materials.

4. Preparing the installation

First step is to prepare the physical installation of the EV Ultra as described in this chapter.

4.1. Installation prerequisites

- Calculate the existing electrical load to find the maximum operating current for the charging station. Note that with the Smappee Overload functionality more charging stations or the total maximum operating current can be higher than the physical installation allows.
- Obtain all necessary permits from the relevant local authority.
- Refer to local wiring regulations to select the conductor sizes and use only copper or aluminium conductors.
- Make sure that the installation area of the charging station is adequate for usability and ventilation purposes.
- Use the correct tools and provide sufficient material resources and protection measures.
- Route the power supply cables to the position where the EV Ultra will be installed together with an Ethernet cable for the internet connection.

	<p>NOTE</p> <p>Make sure that there is at least 100 cm power supply and 100 cm shielded CAT 6 cable length available at the location of the EV Ultra, to be able to connect it easily. For more information, refer to:</p> <ul style="list-style-type: none">• Technical specifications on page 9• Install the EV Ultra anchor on page 17
--	---

4.2. Power supply

- The correct cable section of the supply cable depends on the power rating and distance between the meter cabinet and the charging station. The voltage drop must not exceed 5%. It is advisable to have a maximum voltage drop of 3 %.
- The cable lugs that can be fitted have a width of maximum 35 mm.
- The power supply trajectory from the circuit breaker panel up to the EV Ultra charging station must be protected against short-circuiting and over-current with B or C circuit breakers (or otherwise in compliance with local standards and regulations)
- A charging station must always be connected on a dedicated power circuit.
- Route the power supply cables to the position where the charging station will be installed together with an Ethernet cable for the internet connection.
- Make sure the power supply cables are positioned through the dummy plate of the EV Ultra anchor.

	<p>NOTE</p> <p>All cables enter the charging station through the EV Ultra anchor.</p>
---	--

- Local regulations may be applicable and can vary depending upon the region or country.

4.3. Lifting supplies (not included)

- Crane
- Suitable lifting accessories (four lifting eyes are included)

4.4. Tools (not included)

- Screwdrivers
- Hex keys (2.5 mm, 10 mm)
- Torx key (T30)
- Torque wrench
- 13 mm socket wrench with ratchet handle (for anchor)
- 17 mm socket wrench with ratchet handle
- Wire stripper and cutter
- Needle-nose pliers
- Cable lugs M10 with a maximum width of 35 mm
- Multimeter and earth ground meter
- RJ45 crimping tool

4.5. Supplies (not included)

- Shielded CAT 6 Ethernet cable and two RJ45 connectors for internet access
- Power supply cables
- Spray with airtight material such as polyurethane foam

4.6. Transport, storage and unboxing the EV Ultra

Transport and storage

- Disconnect electrical power supply before removing the charging station for storage or relocation.
- Only transport and store the charging station in its original packaging. No liability for damage incurred will be accepted if the charging station is transported in non-standard packaging.
- Store the charging station in a dry environment within the temperature range specified in the technical specifications.

Unboxing

The EV Ultra is delivered standing on a euro pallet. First remove the cardboard packaging.

Keep in mind to store the cardboard, as this can be used to safely store loose panels while installing the EV Ultra.

4.7. Prepare the foundation of the EV Ultra

Assemble the EV Ultra anchor

The Smappee EV Ultra is designed to be installed at ground level using the supplied anchor. It is mandatory to use this anchor.



NOTE

Only top and bottom of the anchor are specified. There is no specified front or back on the EV Ultra anchor.

To guarantee compact transportation, the anchor is supplied in a kit and needs assembling.

Follow these instructions to assemble the different parts.

1. Disassemble the anchor kit and separate each part.

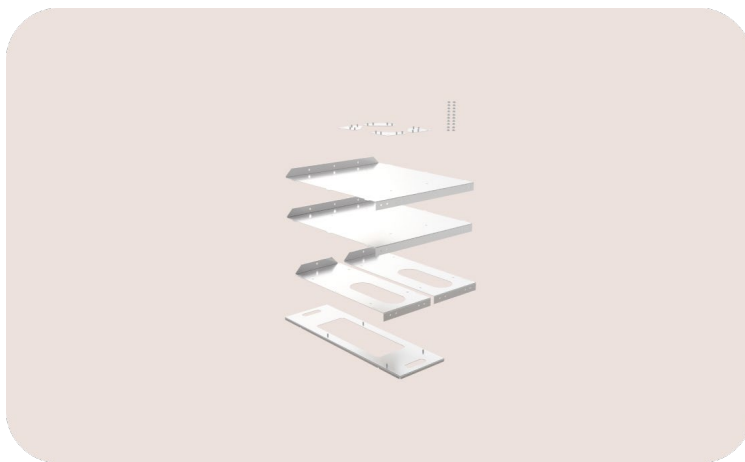

Image 4: Parts of the EV Ultra anchor kit

2. Assemble the plates to the anchor.

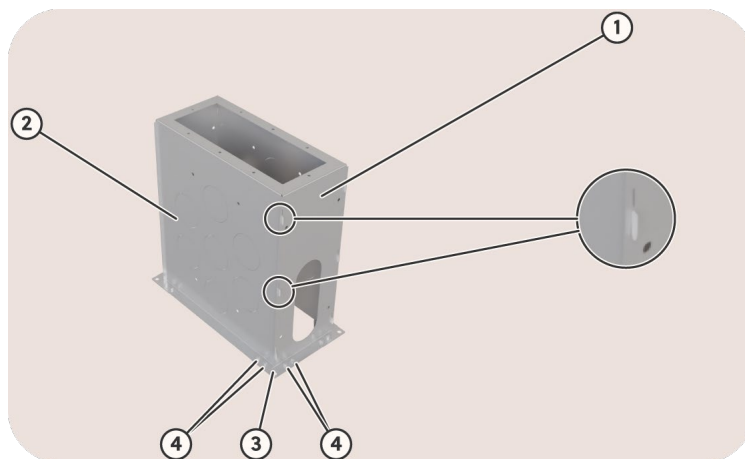

Image 5: View on the anchor assembly

ID	Description	More information
1	Small side plate	The left and right plate are the same and have slotted holes.
2	Wide side plate	The front and rear plate are the same and have hooks to slide in the slotted holes.
3	Bottom plates	These four plates have a bolted connection to the side plates.
4	Fasteners	Tighten the bolted connection manually during this assembly step.

- Put the dummy plate on top of the anchor.
The six studs at the bottom of the dummy plate each fit into a hole in the anchor.

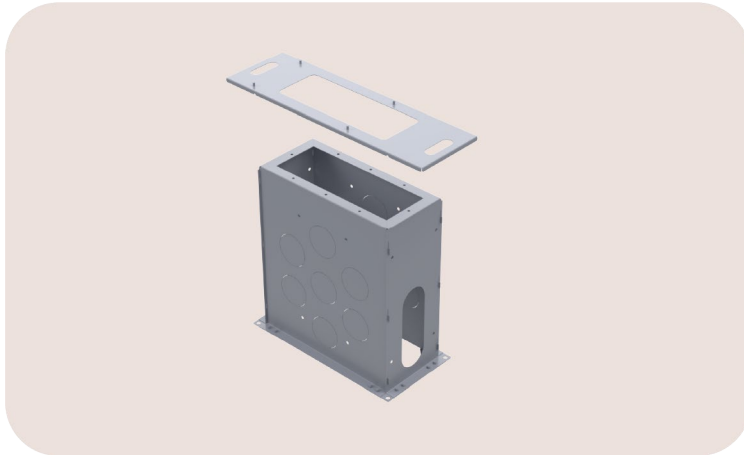

Image 6: View on the dummy plate

- Tighten the fasteners for the four bottom plates.

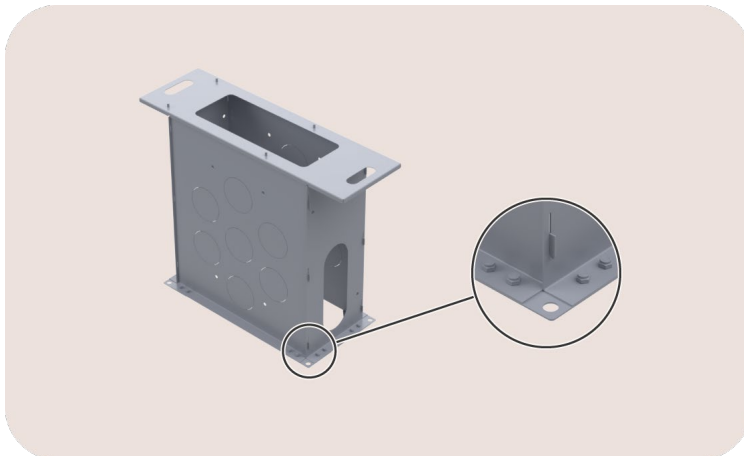

Image 7: View on the fasteners

5. If necessary, remove the round cut-outs.
This can be useful for better fixation of the anchor and for connections to other EV chargers.

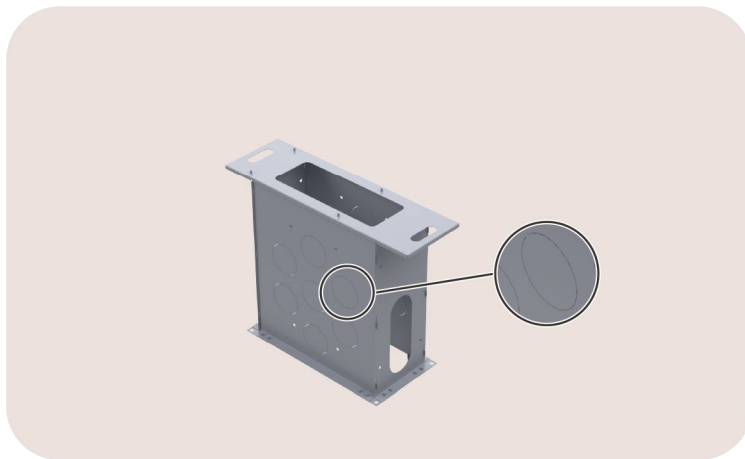

Image 8: View on the cut-outs

As a result, the anchor is ready for installation.

Install the EV Ultra anchor



NOTE

To keep the dimensions of the EV Ultra during the installation of the anchor, there is a dummy plate attached to the top of the anchor. The anchor itself is symmetrical, or in other words, you can select which longest side will be the front..



NOTE

Think about accessibility and usage of the charger for the driver: For example, placed lengthwise in the middle of 2 parking spots.

Make sure that there is sufficient space around the charging station for service and maintenance operations as specified in the IEC 60204-1 standard. This also let adequate airflow for normal operation of the charging station.



NOTE

When dimensioning the foundation, it is advisable to carry out a static load capacity analysis according to the relevant standards.

A stable and level ground needs to be prepared in advance. We advise a levelled concrete foundation at ground level minus the height of the anchor (705 mm).

To correctly install the EV Ultra anchor:

1. Make a foundation hole large enough to accommodate the anchor.
2. Flatten the bottom of the foundation hole by creating a foundation layer made of a dry mixture of sand and cement.
The minimum dimensions of this foundation layer are 450 mm by 750 mm. This is a bit larger than the dimensions of the anchor, to make sure a stable foundation is created.
3. Reinforce the corners of the foundation layer by placing concrete blocks on the foundation layer at the points where the corners of the anchor will be.
Make sure the concrete blocks are level in both directions. If not, adjust until level.
4. Place the EV Ultra anchor on the concrete blocks.
If needed, the anchor can be fixed to the concrete blocks by screwing a bolt in each corner of the anchor (hole diameter \varnothing 16 mm).

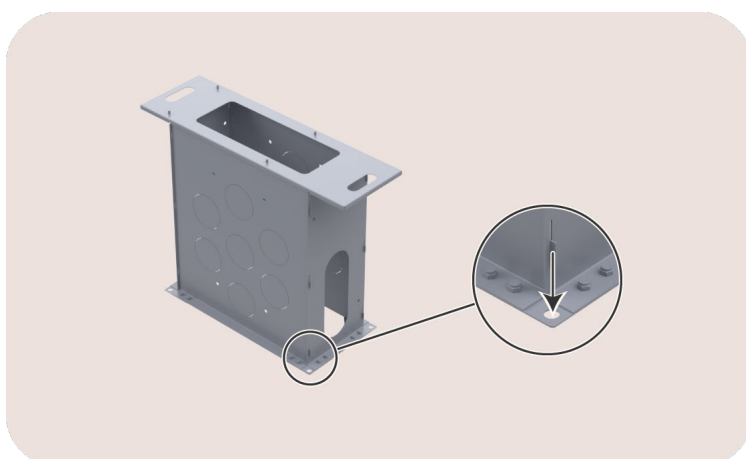

Image 9: View on the anchor fixation

- Route all necessary cables through the anchor. The final location of all cables may already be taken into account here (see picture below).

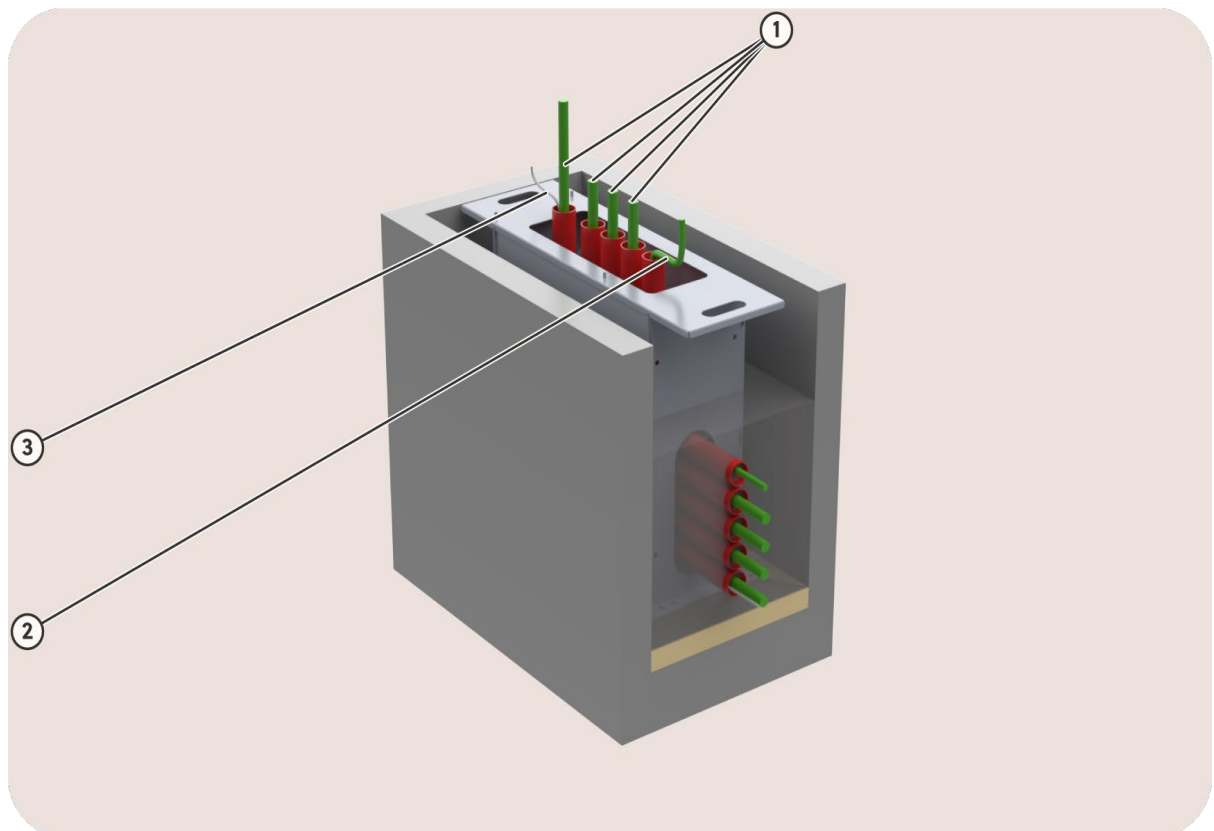

Image 10: View on the cables

ID	Description	More information
1	Power supply cables	For the three phases (L1, L2, L3) and a protective earth (PE) to the inverters. They will be connected at the rear of the EV Ultra, refer to page 24.
2	Auxiliary power supply cable	For the internal electronics of the EV Ultra
3	Ethernet cable	For internet connectivity of the EV Ultra

- Shorten the power supply cables for the inverters to the correct length using a cable cutter. Attach a cable lug over the four shortened cables. Use cable lugs M10 with a maximum width of $A = 35$ mm.

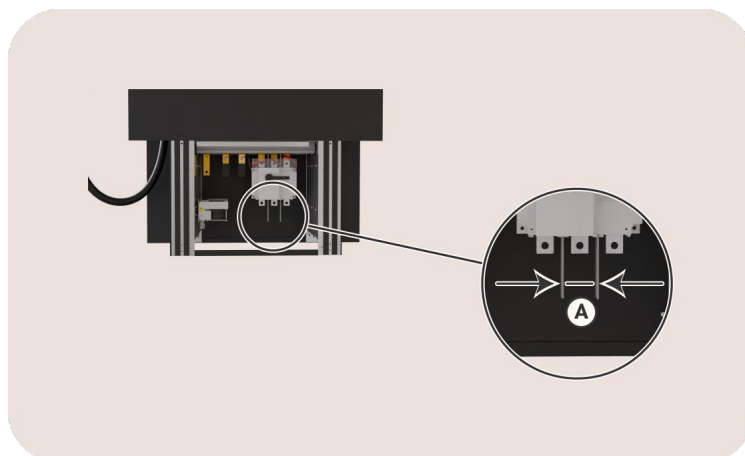

Image 11: View on the connection point of the power supply cables

7. Fill the anchor (A) with concrete (C) until half of the anchor is filled with concrete. It is normal that some excess concrete pours out of the holes. Use this excess to further fix the anchor to the foundation.

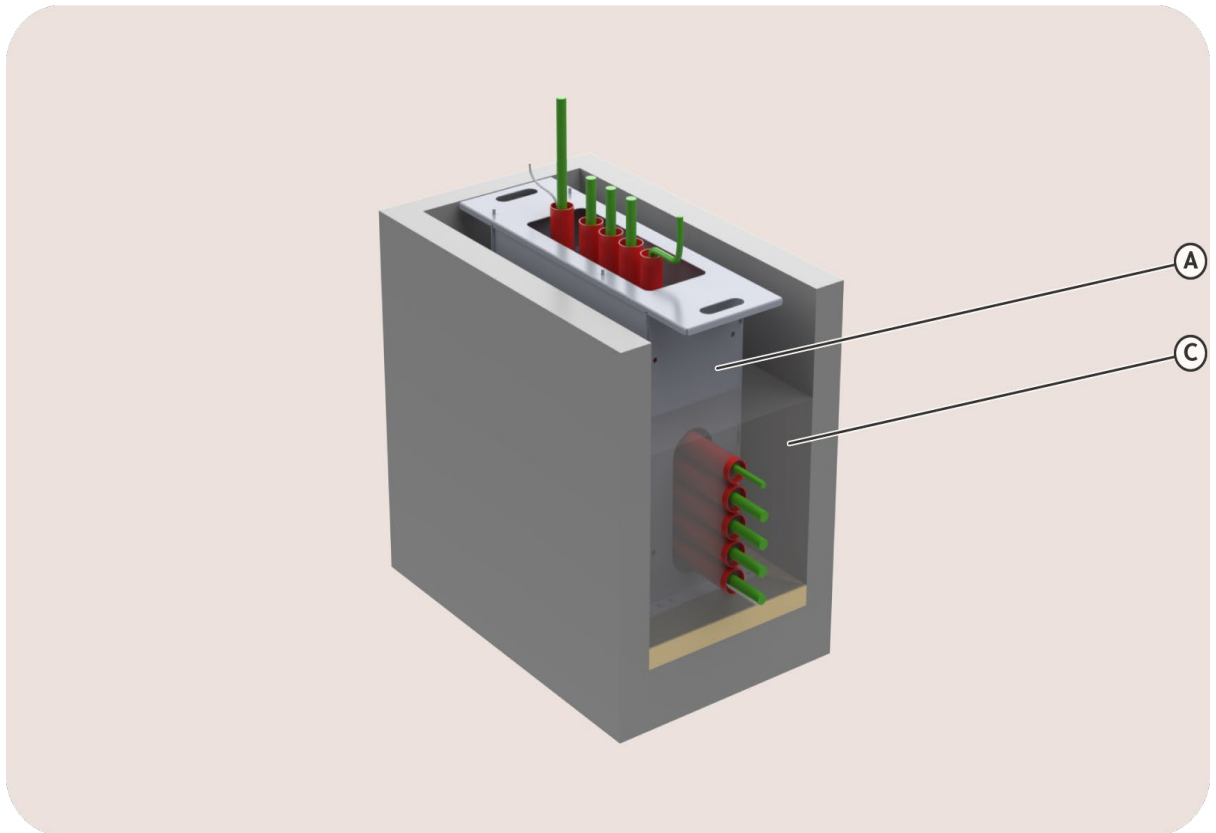









Image 12: View on the installed anchor

Wait for the concrete to cure before going to the next steps.

5. Installation and configuration

	<p>CAUTION</p> <p>The installation must be carried out by a qualified professional who has read this manual and works in compliance with IEC 60364 standards. Neglecting this may lead to severe injuries or hazardous situations while working with electricity.</p>
	<p>CAUTION</p> <p>The electric system must be entirely disconnected from every power source prior to performing installation or maintenance work. Make sure it is not possible to connect the electric current during installation. Put up caution tape and warning signs to mark the work areas. Make sure no unauthorised people can enter the work areas.</p>
	<p>CAUTION</p> <p>Hazardous electrical voltages are present in the EV Ultra (up to 1000 V).</p>
	<p>CAUTION</p> <p>The charging station contains electric components that may still contain electrical charge after being disconnected. Wait at least 10 seconds after disconnection before commencing work.</p>
	<p>CAUTION</p> <p>Adaptors or conversion adaptors and cord extension sets are not allowed to be used.</p>
	<p>CAUTION</p> <p>The EV Ultra contains components and circuits boards sensitive to electrostatic discharge. Sufficient electrostatic discharge measures should be taken to protect the components during installation and maintenance.</p>
	<p>CAUTION</p> <p>Components of the EV Ultra can be very heavy, for example the inverters.</p>
	<p>CAUTION</p> <p>Take care that components don't squeeze a human body or body part while assembling or disassembling.</p>

This procedure describes the required steps for the physical installation of the EV Ultra.

1. Prepare the EV Ultra for lifting (page 21)
2. Position the EV Ultra (page 23)
3. Attach the EV Ultra (page 24)
4. Connect the power supply to the inverters (page 24)
5. Connect the auxiliary power supply (page 25)
6. Connect the EV Ultra to the internet (page 26)
7. Start the power supply to the inverters (page 28)
8. Complete the installation (page 28)
9. Configure the EV Ultra with the Smappee App (page 29)

5.1. Prepare the EV Ultra for lifting

The EV Ultra is delivered standing on a euro pallet. To position the EV Ultra, do the following:

1. Remove the dummy plate from the top of the anchor.
This dummy plate was used during the installation of the anchor, but is not longer necessary.
2. Remove the cardboard packaging.
3. Attach the lifting eyes on the top of the EV Ultra.

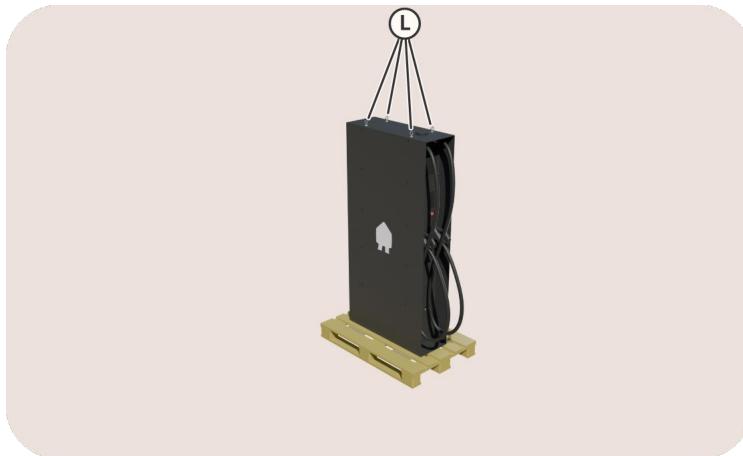

Image 13: View on the lifting eyes

The lifting eyes are in the included accessory box.

The four M10 bolts that hold the top plate, can be removed without tools.

Make sure you keep the bolts and rubber washers.

4. Put a little tension on the lifting loops, to prevent the EV Ultra from falling over.
Use a suitable crane and lifting loops with carabiners.

5. Remove the rear plate (A) and side plates (B, C).

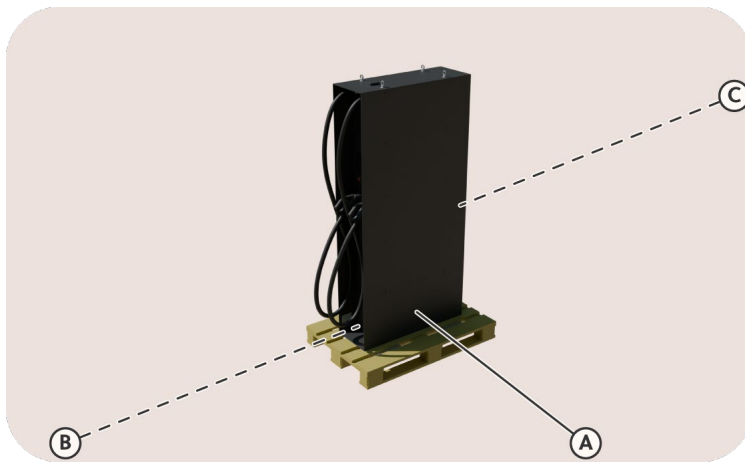

Image 14: View on the plates

The rear side of the EV Ultra is the side without the Smappee logo.

Put the plates in a safe location where they cannot be scratched or damaged.

6. Remove the plates (P) that hold the EV Ultra on the euro pallet.
The bolted connection can be loosened with a 17 mm key for the hex nut at the top and a 10 mm key for the hexagon socket screw at the bottom.

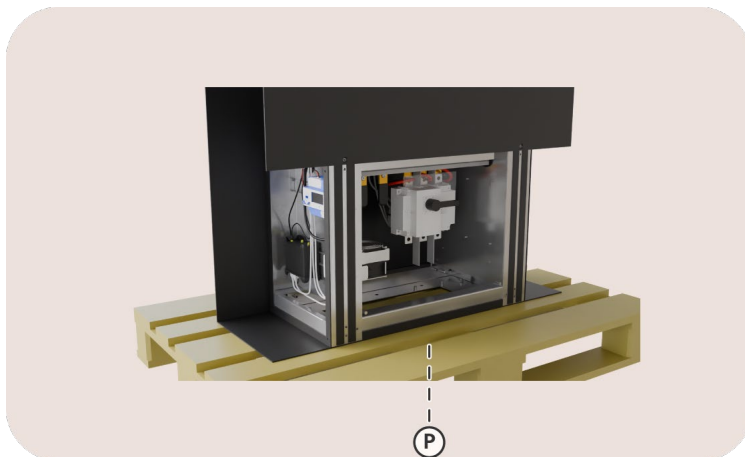

Image 15: View on the bottom

5.2. Position the EV Ultra

Instructions

1. Lift the EV Ultra with the crane.
2. Put a screw (M8 x 40) in each threaded hole.
These screws will be used to align the EV Ultra with the anchor.

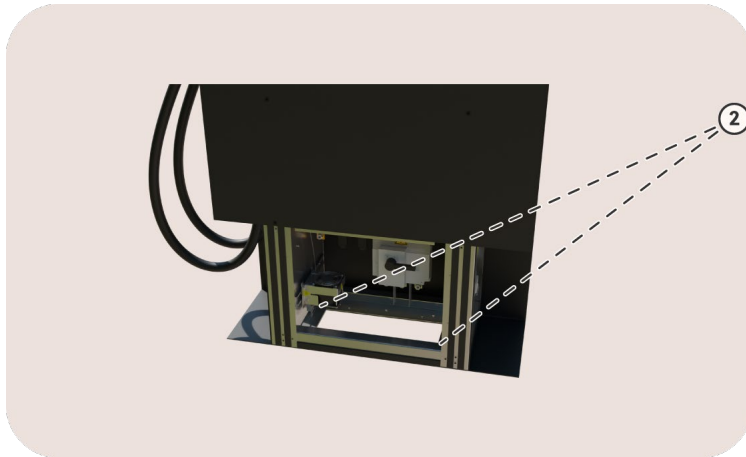

Image 16: View on the alignment screws

3. Move the EV Ultra with the crane above the anchor.

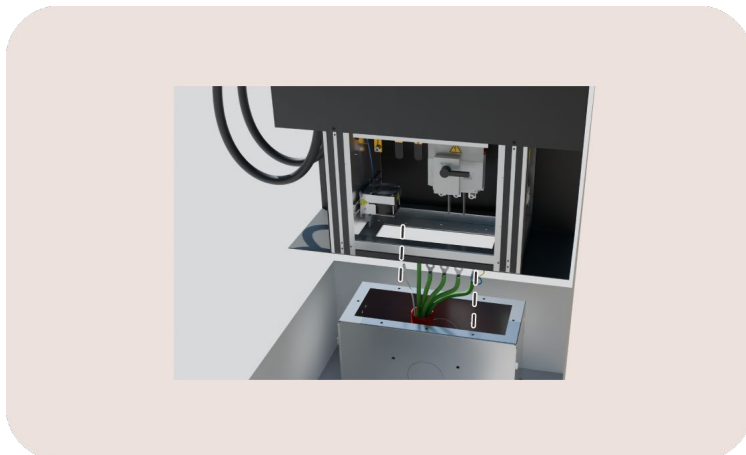

Image 17: View on the position

Make sure that all cables go through the opening, while keeping the final position.
Make sure no cable can be crushed during lowering the EV Ultra.

5.3. Attach the EV Ultra

Instructions

1. Put the other fasteners to connect the EV Ultra to the anchor.

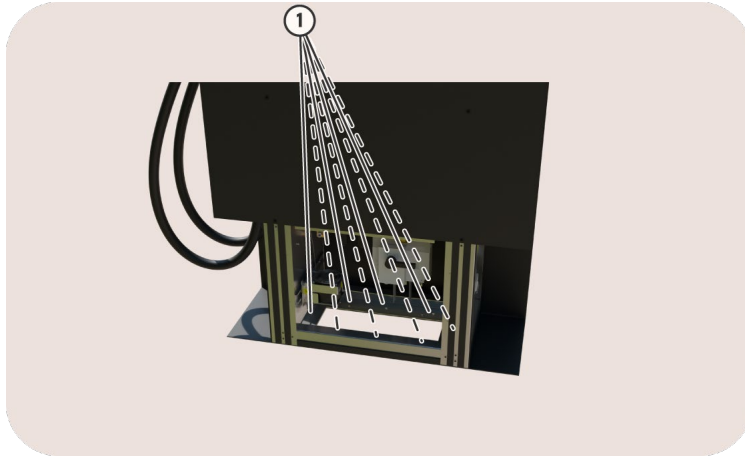

Image 18: View on the attachment points

2. Tighten the fasteners manually to prevent the EV Ultra from falling over.
3. Remove the tension from the lifting loops.
4. Tighten the fasteners to a torque of 40 Nm.
5. Remove the lifting loops.
6. Replace the eye bolts on top of the EV Ultra again with the four originally fitted bolts. Make sure a washer of rubber is still fitted around each bolt to prevent water seeping into the charging station. Do not use more than 8 Nm of torque.

5.4. Connect the power supply to the inverters

Context

The power supply to the inverters is used for the DC charging.

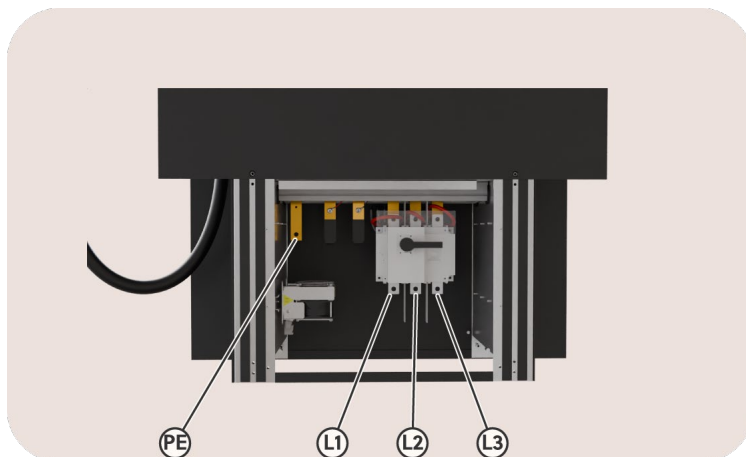

Image 19: View on the power supply to the inverters

Instructions

Proceed as follows.

1. Loosen the two screws from the plastic cover with a cross-head screwdriver.
2. Remove the plastic plate from the load break switch.
3. Connect the three phase cables to the load break switch and the PE cable to the left bus bar.
4. Tighten the bolted connections to a torque of 40 Nm.
5. Put the plastic cover back on the load break switch.

5.5. Connect the auxiliary power supply

Context

The auxiliary power supply is used for power supply to the AC-parts of the charging station that doesn't need high power for DC-charging.

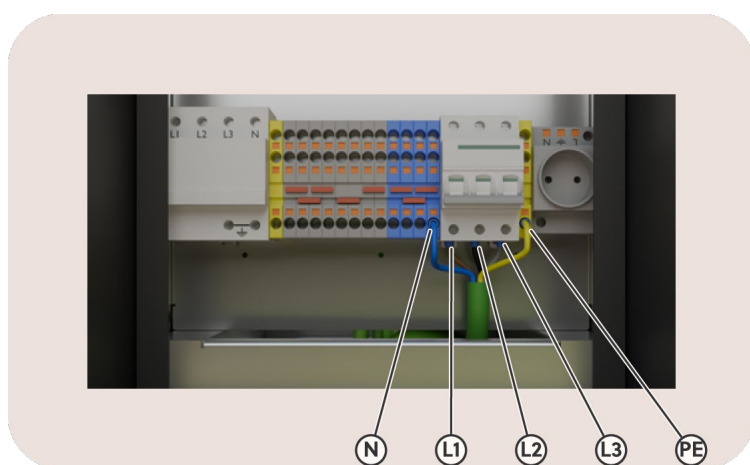

Image 20: View on the auxiliary power supply

ID	Description	More information
L1	Brown conductor	The three phases go into the internal 3P 10 A circuit breaker.
L2	Black conductor	
L3	Grey conductor	
N	Blue conductor	The neutral (N) and protective earth (PE) conductor go into the terminal blocks.
PE	Green/yellow conductor	

Instructions

Proceed as follows.

1. Shorten the 5G2.5 mm² cable to the necessary length.
2. Put each conductor in the corresponding connection opening.
Make sure each conductor goes to the indicated connection opening.

5.6. Connect the EV Ultra to the internet

Context



CAUTION

Risk of electric shock.

Make sure no tools are in the charging station and people stand free from the charging station.

Instructions

Proceed as follows.

1. Put the Ethernet cable in the open WAN port on the bottom right side of the router.



Image 21: View on the left side

A router creates a small, private network within the EV Ultra to provide network connectivity for all components. This private network is created within the subnet 192.168.37.0. There is a 4G connection configured as backup, in case of failure of the wired internet connection.

2. Make sure that the circuit breaker is set to the on position.
3. Start the power supply to the auxiliary power supply cable.
4. Check the status of the components after approximately 30 seconds.



Image 22: View on the left side and right side

ID	Description	More information
1	Smappee Power Box	Flashing 1 time per 3 seconds
2	Smappee Connect	Blue flashing, 1 time per second
3	Router	Signal strength indicator

5.7. Start the power supply to the inverters

Context



CAUTION

Risk of electric shock.

Make sure no tools are in the charging station and people stand free from the charging station.

Instructions

Proceed as follows.

1. Make sure that the load break switch is set to the on (I) position.
2. Start the power supply to the power supply cable.
3. Complete the installation.

5.8. Complete the installation

Context



CAUTION

Risk of electric shock.

Switch off electrical power supply to your charging station before installation or maintenance work.

Instructions

Proceed as follows.

1. Fill the opening between the anchor and charging station with an airtight material such as polyurethane foam.
This is to prevent the overpressure from the cooling fans escaping into the ground, to stop small animals from entering the charging station via the ground and to avoid moisture problems.
2. Put the rear plate back.
3. Configure the EV Ultra with the Smappee App (page 29).
4. Put the side plates back.

5.9. Configure the EV Ultra with the Smappee App

Prerequisites

This procedure is done with the Smappee App. You can download this mobile app from the Apple App Store for iOS or the Google Play store for Android phones.



Image 23: Download the Smappee App

Instructions

1. For the installation of the first Smappee product, go to **Home** > + button > **I want to install a Smappee charging station**.
For the addition of an EV Ultra to an existing Smappee location, go to **Settings** and then:
 - For a first installation to this location: **Install a Smappee EV Line charging station**
 - For an additional charging station at this location: **Your charging stations** > + button
2. Follow the steps shown in the Smappee App.
3. Put the side plate back, refer to Complete the installation (page 28).

Post-requisites

The **Name** and **Maximum power for each connector** of your charging station can be adjusted in the Smappee App or the Smappee Dashboard.

The EV Ultra must be commissioned by Smappee before the first use.

For more information, refer to [this help center article](#) and the EV Ultra training on [Smappee Academy](#).

6. Maintenance

For a safe and regular operation of the EV Ultra, regular maintenance or control is required. Refer to the table below for the intended maintenance work and interval.

All points in the table are considered mandatory and must be carried out by a certified technician.

Before starting maintenance activities, consider all safety precautions as listed in:

- Safety instructions (page 5)
- Installation and configuration (page 20)

6.1. Maintenance schedule

- Observe the maintenance schedule in the table below.
- Clean the outside only with a dry, clean cloth.
- Do not use abrasive agents or solvents.
- May not be carried out during rain or if air humidity exceeds 95%.

	<p>WARNING</p> <p>Fully read and follow the safety instructions below before you install, service or use your EV Ultra. Incorrect installation, repairs or modifications can result in danger to the user and may void the warranty and liability.</p>
---	---

Maintenance task	Interval	More information
Check the compliance.	Every maintenance activity	Refer to local regulations and standards.
Check the visual state.	Every maintenance activity	If necessary, replace worn or damaged parts.
Replace the charging cable.	After 20,000 charging cycles	Article number: 30-0206
Do a functional test of the load break switch.	Every maintenance activity	Set the load breaker switch to off. Check that there is no power supplied to the inverters. If necessary, replace the load breaker switch.
Do a visual inspection of the overvoltage fuse to each inverter.	Yearly	Stop the power supply before you open the charging station fuse holder. Do a visual inspection of each fuse. If necessary, replace the fuse. Article number: 100-0076
Do a functional test of the overvoltage circuit breaker of the auxiliary power supply.	Yearly	Set the switch to off. Check that there is no power supplied. If necessary, replace the overvoltage circuit breaker. Article number: 260-0039
Verify the protective measures.	Yearly	With the charging station switched off, check the resistance between the ground and all externally accessible parts. This can be housing, screws, and other parts.
Check the tightening torque of bolts.	Yearly	With stopped power supply to the charging station, check the tightening torque of the load break switch bolts (6x:

Maintenance task	Interval	More information
		for each phase cable, before and after the load break switch). Also do a visual inspection of the connection of the cables to the bus bar. The marker on the bolt must be aligned with the marker on the bus bar.
Check for cleanliness and condensation	Yearly	Stop the power supply before you open the charging station. If necessary, clean with a dry, clean cloth. Do not use abrasive agents or solvents. If necessary, replace the sealant of the openings. Refer to page 28.
Ventilation filters	Yearly	Replace the filters of the EV Ultra with article numbers: 100-0102 back top 100-0103 back bottom 100-0104 inverter outlet

6.2. Inverter fault codes

Fault code	Analysis	Solution
E02	Fan blocked	Remove the object that prevents the fan.
	Air duct blocked	Remove the object that blocks air duct or clear dust.
E03	AC input voltage is not in the normal range	Ensure AC input voltage is in the normal range
E05	Module positive and negative pole short circuit	Power off the control module, check whether the positive and negative poles on the output circuit are short circuited, and reboot after confirming that there is no short circuit. If alarm persists, replace control module.
E06	Module output voltage exceeds the set output overvoltage value	Power off the control module, check whether the module output voltage has been changed, and check that the module output voltage is less than the set module output overvoltage value. And then, reboot after pulling out the control module, if alarm persists, replace control module.
E07	Address conflict	Reboot the charging station. If the error persists, contact support.
E09	The difference between the module current and average current is too large	Check the control module communication, check the connection of the communication cable. If the communication is good and alarm persists, replace the control module.

Annexes

Performance graphs EV Ultra Dual

The following graph shows the DC output power for a charging point, related to the AC input line voltage.

No DC output power is produced if the AC input voltage is below 285 V or above 475 V. Small variances in the normal AC input voltage (for example between 400 V and 410 V) will not cause any change in the DC output power.

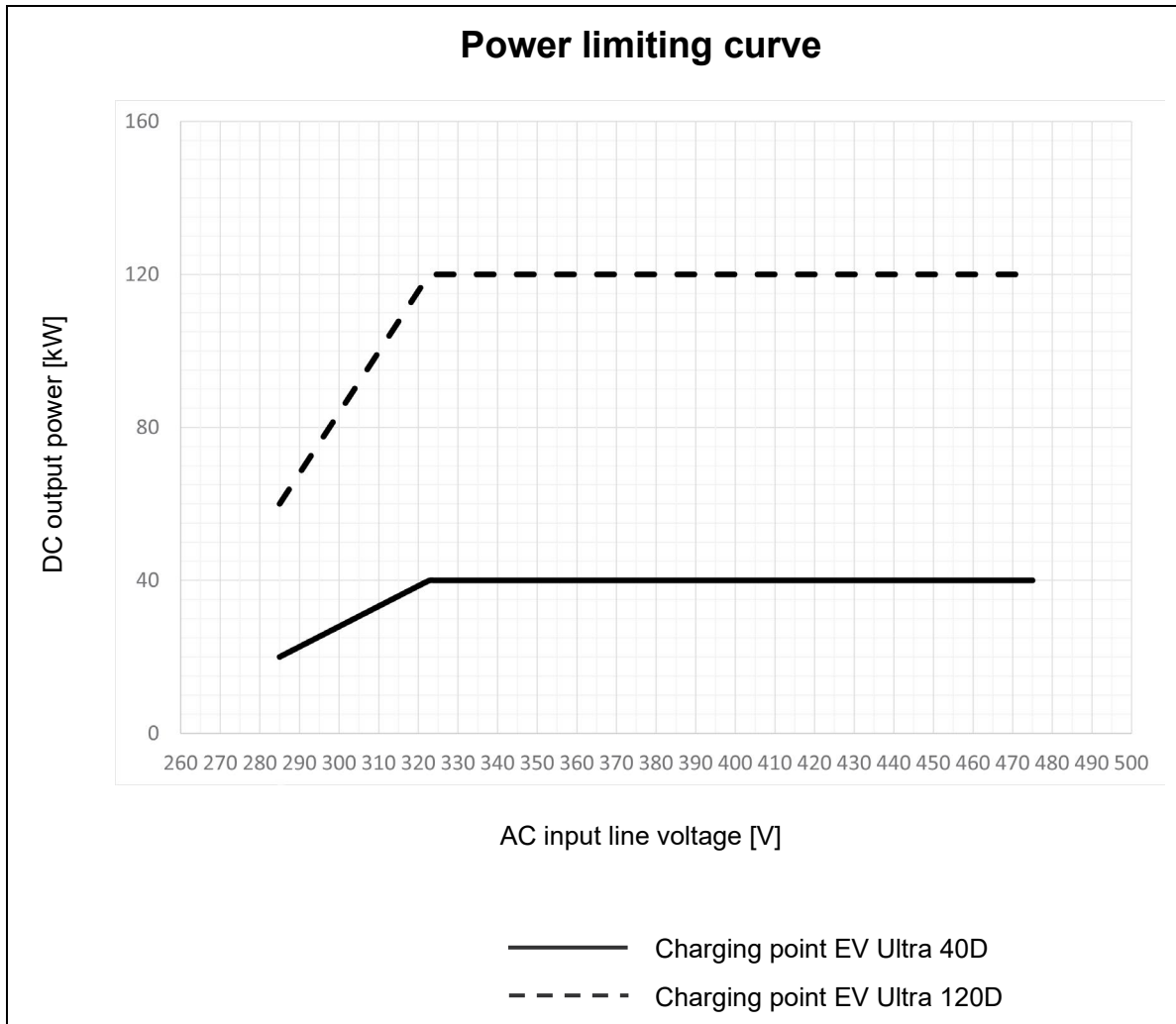

The following graph shows the maximum output current for a charging point as a function of the output voltage. The output voltage is determined by the vehicle's battery, where most vehicles require voltages of approximately 400 V or 800 V. The Smappee EV Ultra can provide voltages between 100 V and 1000 V.

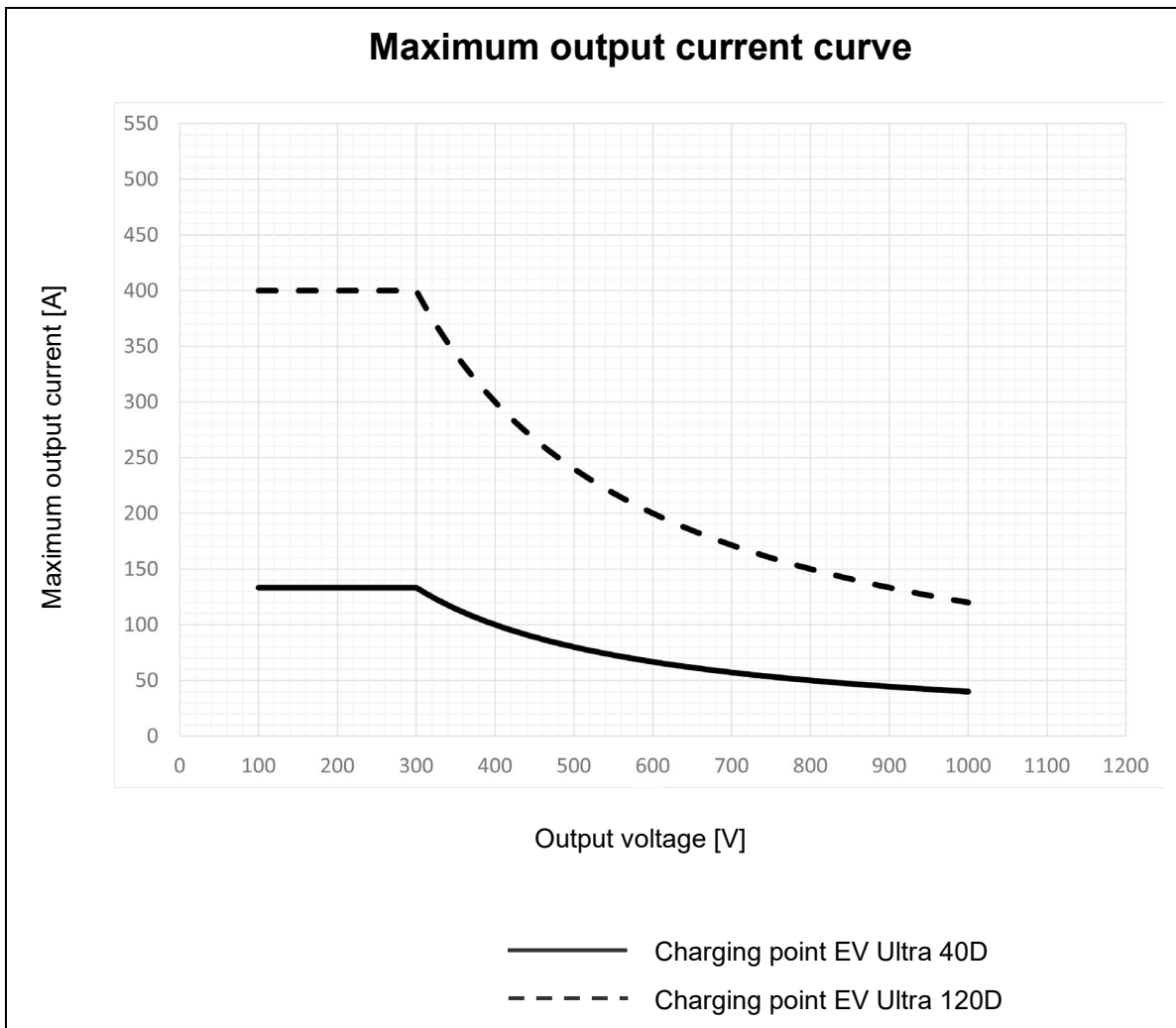

Power derating graph EV Ultra Dual

The following graph shows the decrease in power output per charging point as a function of temperature increase in the inverters of the different EV Ultra.

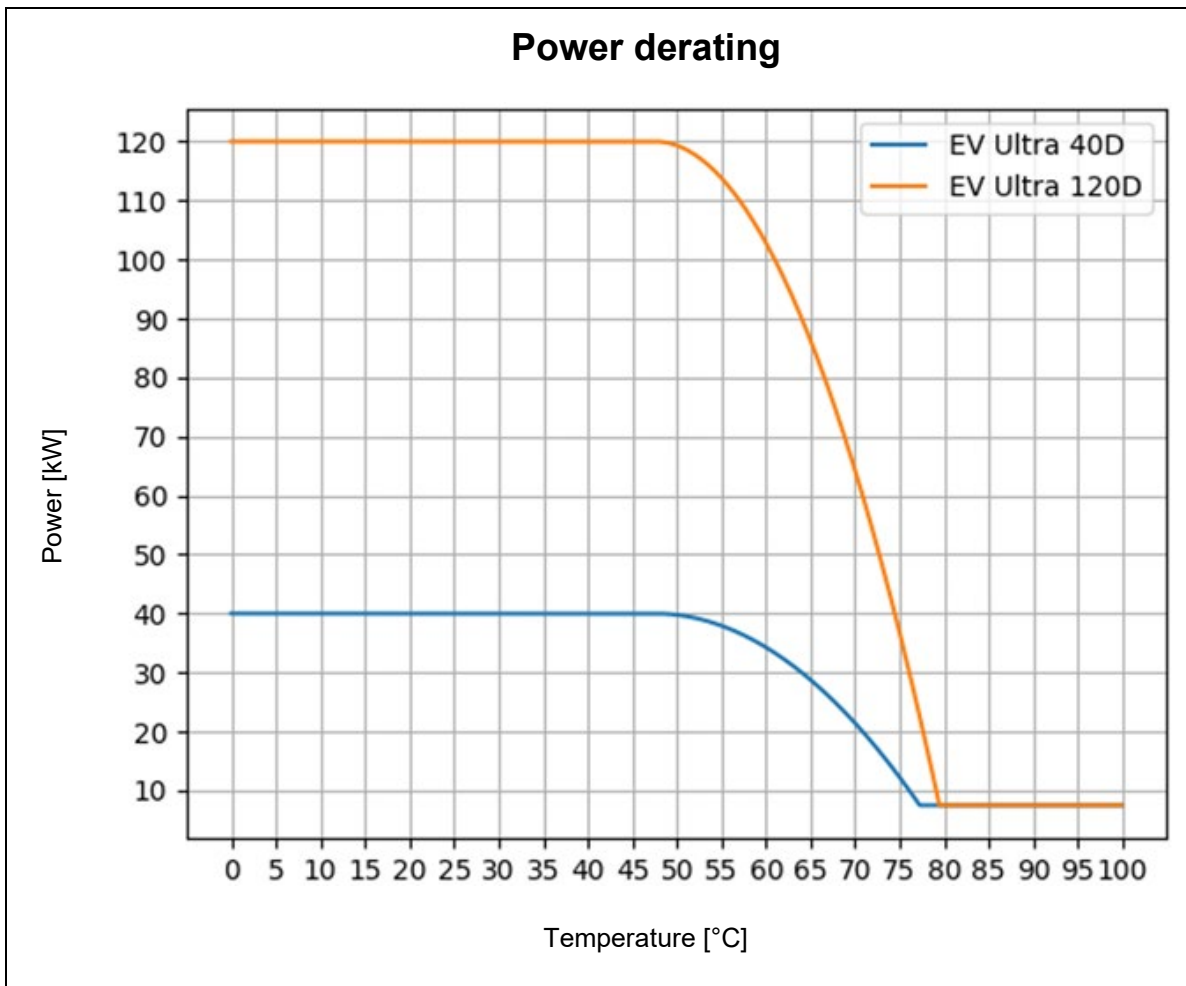

Declaration of conformity

Declaration of conformity

We,
Smappee nv
Evolis 104
B-8530 Harelbeke, Belgium

following the provision of the following EC Directives:

- 2014/35/EU The Low Voltage Directive
- 2014/30/EU The Electromagnetic Compatibility Directive
- 2011/65/EU RoHS Directive

hereby declare that the product:

EVU-80D-C3-B, EVU-80D-C3-W, EVUE-80D-C3-B, EVUE-80D-C3-W,
EVU-240D-C3-B, EVU-240D-C3-W, EVUE-240D-C3-B, EVUE-240D-C3-W

is in conformity with the applicable requirements of the following documents

- Emissions:
(EN61326-1 : 2013)
Radiated Emission: EN 55011:2009 / EN 55032:2015 (Class B)
Conducted Emission: EN 55011:2009 / EN 55032:2015 (Class B)
Harmonic current Emission: EN 61000-3-2:2005 +A1:2008 + A2:2009
Flicker: EN 61000-3-3:2008
- Immunity:
(EN61326-1 : 2013)
ESD : EN 61000-4-2:2008 / EN 61000-4-2 :2009
Radiated immunity : EN 61000-4-3:2006 + A1:2007 + A2: 2010
Power frequency magnetic field: EN 61000-4-8:2009
Voltage dips/interruptions: EN 61000-4-11:2004
Common Mode Immunity: EN 61000-4-6:2008 / EN 61000-4-6:2009
Burst : EN 61000-4-4:2004 / EN 61000-4-4:2012
Surge: EN 61000-4-5:2005 / EN 61000-4-5:2006
- Safety:
Metering Function : IEC 61010-1 Ed 3.0 (2010-06) + A1:2016
AC Charging equipment : IEC 61851-1 (2017) / EN61558-1
- Other applicable standards and certifications:
IEC 60364, IEC 62192-1, IEC 62192-2, AS/NZS 3820:2020

Harelbeke, Belgium, March 1th, 2024

Authorized signatory



CEO Smappee

