

EV Dual

Install and operate guide

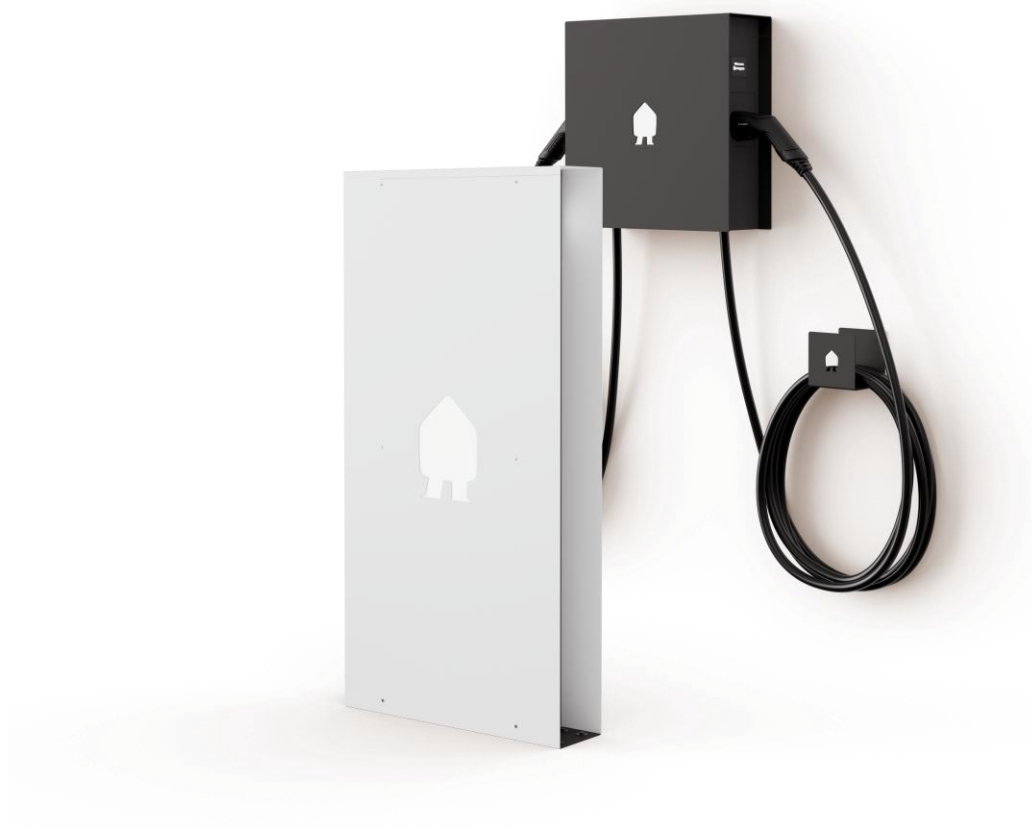

Document accuracy

The specifications and other information in this document were verified to be accurate and complete at the time of its publication. Due to ongoing product improvement, this information is subject to change at any time without prior notice. For the latest information, see our online documentation: smappee.com/downloads

Table of contents

1	Introduction.....	4
2	Safety instructions.....	5
3	Overview of the EV Dual.....	7
4	Prepare the installation.....	24
5	Installation and configuration.....	39
	Annexes.....	51

1 Introduction

Thank you for purchasing this EV Dual charging station for electric vehicles, the smartest charging station.

This installation manual tells you how to install the EV Dual. We recommend that you read the contents of this manual carefully, to ensure a safe and proper installation and enable to use all the advanced features of this product to the full.

Intended use

This charging station is designed for charging electric vehicles using either the fixed Type 2 charging cable (with shutter) or a compatible Type 2 charging cable connected to the socket outlet. The use of intermediate adapters or extension cables is not permitted.

Use for any other purpose than EV charging as defined in the IEC 61851-series is not allowed and constitutes misuse of the charging station. Only qualified, trained and authorised persons are allowed to install, maintain and/or repair the charging station and make sure that the technical specifications and installation requirements are met. Incorrect installation and testing of the charging station could potentially damage either the vehicle's battery or the device. Any resulting damage is excluded from the warranty of the device. Any modification that is not in writing confirmed by Smappee will void the warranty. For more information, refer to smappee.com/legal-documents.

Support

Only qualified electricians or equivalent may install the charging station. If you have any questions, please contact your service partner.

Please have the following information ready to hand to speed up the process: Article number and serial number which you can find on the identification label of the charging station.





Should your local distributor be unable to help you, or you have a suggestion for us, you can contact Smappee at: **support@smappee.com**.

Smappee NV
Evolis 104
8530 Harelbeke
Belgium

2 Safety instructions

2.1 Safety warnings and precautions

	<p>WARNING</p> <p>Carrying out activities on this charging station without the relevant knowledge and qualifications can lead to serious accidents and death. Only carry out tasks for which you are qualified and have been fully instructed.</p> <p>Only certified electricians may carry out the installation, which must be in accordance with the national safety regulations.</p> <p>Fully read and follow the safety instructions below before you install, service or use your EV Dual. Incorrect installation, repairs or modifications can result in danger to the user and may void the warranty and liability.</p>
	<p>CAUTION</p> <p>Risk of electric shock.</p> <p>Refer to the accompanying documentation whenever you see this symbol.</p>

Please observe the following safety precautions to avoid potential electric shock, fire, or personal injury:

- Use the correct tools and provide sufficient material resources and protection measures.
- The charging station is, when installed correctly, intended to be used by untrained individuals to exclusively charge their electric vehicle.
- Do not allow children to operate a charging station.
- When a charging station is in use, adult supervision of any children present is required.
- Switch off electrical power supply to the charging station before installation or maintenance work.
- Do not use the charging station if it is damaged or defective.
- Do not immerse the charging station in water or any other liquids.
- Do not expose the charging station to heat, flame or extreme cold.
- Do not attempt to open, repair, or service any parts. Contact Smappee or your service partner for further information.
- Only use the charging station under the specified operating conditions.
- While charging the charging cable must be completely unwound and connected to the electric car without overlapping loops. This to avoid the risk of overheating the charging cable.
- After charging, store the charging cable properly so it does not present a tripping hazard. Make sure the charging cable cannot become damaged (kinked, compressed or driven over).
- Do not place any objects on the charging station.

2.2 Maintenance

- Observe the maintenance schedule (page 52).
- Clean the outside only with a dry, clean cloth.
- Do not use abrasive agents or solvents.
- May not be carried out during rain or if air humidity exceeds 95 %.





2.3 Transport and storage



- Disconnect electrical power supply before removing the charging station for storage or relocation.
- Only transport and store the charging station in its original packaging. No liability for damage incurred will be accepted if the charging station is transported in non-standard packaging.
- Store the charging station in a dry environment within the temperature range specified in the technical specifications.

3 Overview of the EV Dual





3.1 Models

The EV Dual has a modular design, where each installed product has an EV Dual Core that can be attached to a pedestal or a wall mounting plate. The EV Dual is completed with two (shutter) charging cables, if applicable, and a white or black housing.

EV Dual cable version	
Image	Description
	EV Dual Base Black with Cables
	EV Dual Base White with Cables
	EV Dual Wall Black with Cables
	EV Dual Wall White with Cables

EV Dual Socket version	
Image	Description
	EV Dual Base Black
	EV Dual Base White
	EV Dual Wall Black



















	EV Dual Wall White
---	--------------------

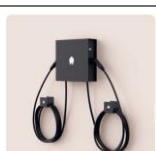



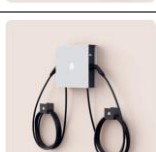







EV Dual cable with shutter version	
Image	Description
	EV Dual Base Black with shutter Cables
	EV Dual Base White with shutter Cables
	EV Dual Wall Black with shutter Cables
	EV Dual Wall White with shutter Cables

For more information, refer to What's in the boxes (page 11).



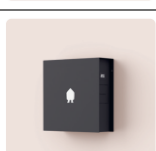

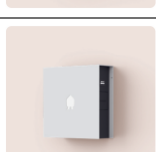













The EV Dual is assembled using components from different boxes. The necessary boxes are related to the model to be installed.

The following table shows per row the article numbers of the boxes related to the installed product.

EV Dual cable version				
Installed product	Core	Pedestal	Plates	Charging cables
	EVD-2332-C5 	EVD-FLOOR-PEDESTAL 	EVD-FLOOR-KIT-B 	EVD-FLOOR-2C5 
	EVD-2332-C5 	EVD-FLOOR-PEDESTAL 	EVD-FLOOR-KIT-W 	EVD-FLOOR-2C5 
	EVD-2332-C5 	N/A	EVD-WALL-KIT-B 	EVD-WALL-2C5 
	EVD-2332-C5 	N/A	EVD-WALL-KIT-W 	EVD-WALL-2C5 

EV Dual Socket version				
Installed product	Core	Pedestal	Plates	Charging cables
	EVD-2332-B 	EVD-FLOOR-PEDESTAL 	EVD-FLOOR-KIT-B 	N/A
	EVD-2332-B 	EVD-FLOOR-PEDESTAL 	EVD-FLOOR-KIT-W 	N/A
	EVD-2332-B 	N/A	EVD-WALL-KIT-B 	N/A
	EVD-2332-B 	N/A	EVD-WALL-KIT-W 	N/A

EV Dual cable with shutter version

Installed product	Core	Pedestal	Plates	Charging cables
	EVD-2332-C5 	EVD-FLOOR-PEDESTAL 	EVD-FLOOR-KIT-B 	EVD-FLOOR-2CS8 
	EVD-2332-C5 	EVD-FLOOR-PEDESTAL 	EVD-FLOOR-KIT-W 	EVD-FLOOR-2CS8 
	EVD-2332-C5 	N/A	EVD-WALL-KIT-B 	EVD-WALL-2CS8 
	EVD-2332-C5 	N/A	EVD-WALL-KIT-W 	EVD-WALL-2CS8 

3.2 What's in the boxes

Box with the EV Dual Core

- 1 Identification sticker on the box

 **NOTE**
Variants:

- [EVD-2332-B] EV Dual Core Socket
- [EVD-2332-C5] EV Dual Core Cable



Image 1: Content of the box with the core assembly for a socket model

ID	Quantity	Description
1	1	EV Dual Core
2	1	Starter box
3	1	Cable gland + nut M32
4	1	Cable gland + nut M20
N/A	1	Quick install guide

Box with the pedestal for the EV Dual Base

2  Identification stickers on the box

This [EVD-FLOOR-PEDESTAL] EV Dual Base Pedestal is only necessary for the ground-mounted charging station.

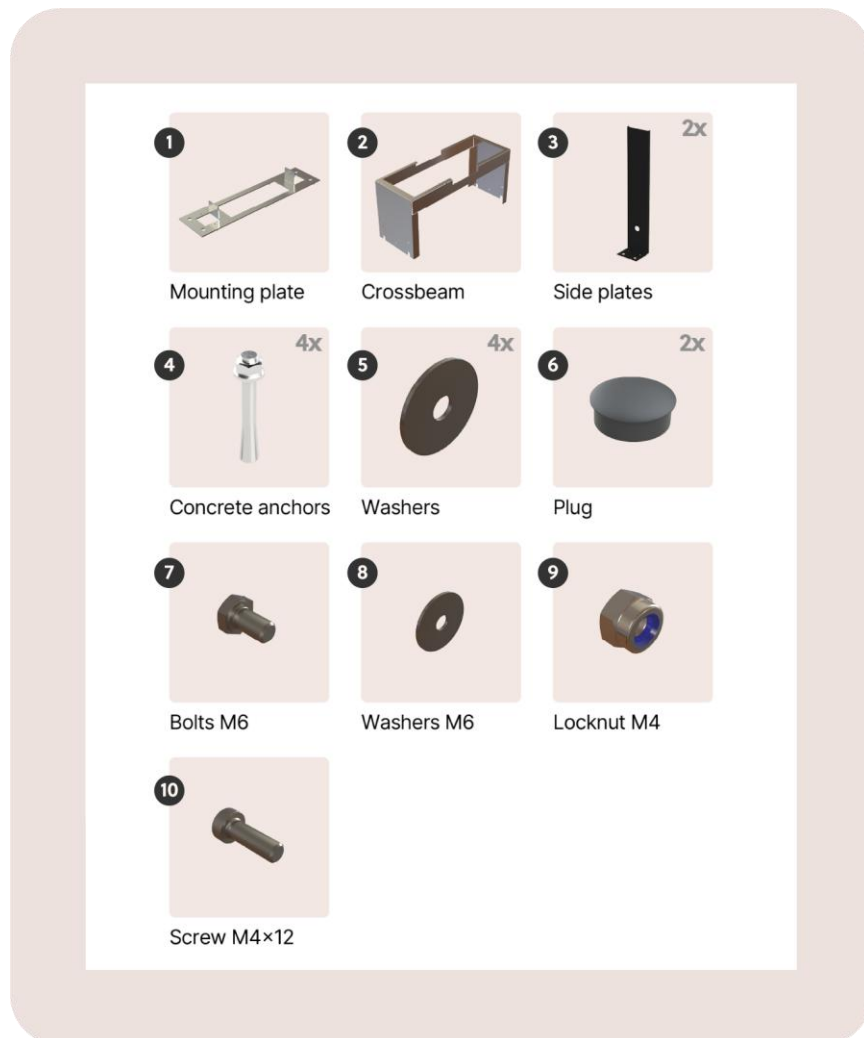

Image 2: Content of the box with the pedestal

ID	Quantity	Description
1	1	Mounting plate
2	1	Crossbeam
3	2	Side plates
4	4	Concrete anchors
5	4	Washers
6	2	Plug
7	4	Bolts M6
8	4	Washers M6
9	6	Lock nut M4
10	4	Screw M4x12

Box with the plates for the EV Dual Base

3 Identification stickers on the box



NOTE

Variants per colour:

[EVD-FLOOR-KIT-B] EV Dual Base plate kit Black

[EVD-FLOOR-KIT-W] EV Dual Base plate kit White

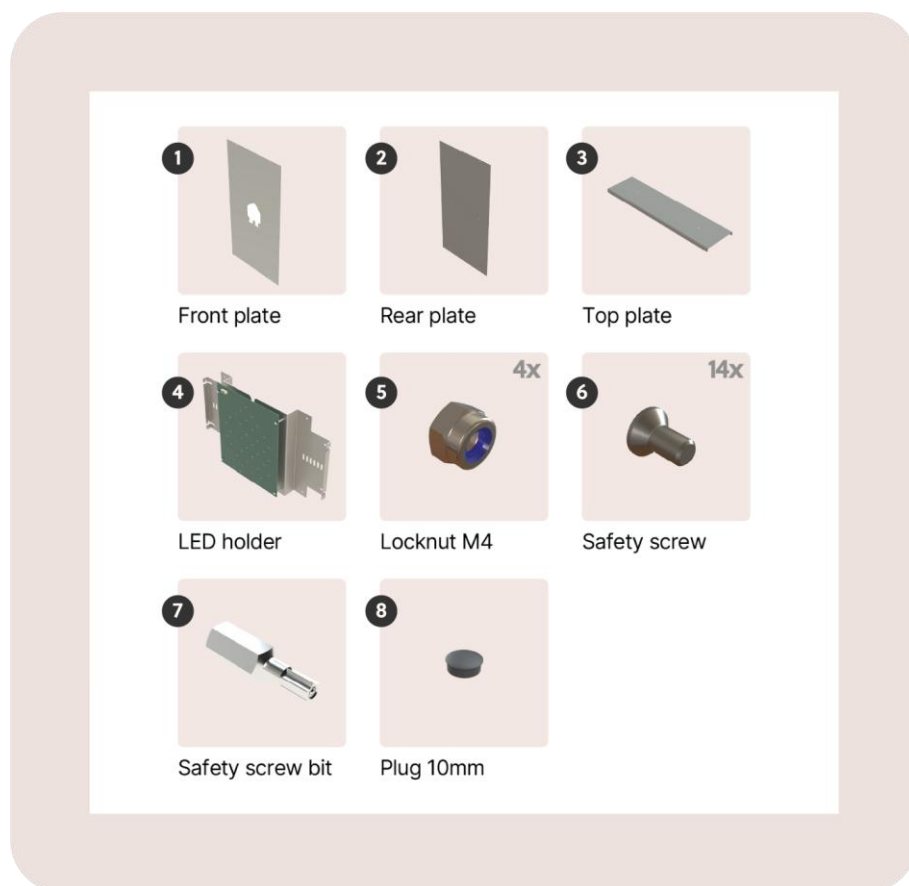



Image 3: Content of the box with the plates

ID	Quantity	Description
1	1	Front plate
2	1	Rear plate
3	1	Top plate
4	1	LED holder
5	4	Lock nut M4
6	14	Safety screw
7	1	Safety screw bit

Box with the charging cables for the EV Dual Base

4  Identification stickers on the box

[EVD-FLOOR-2C5] EV Dual Base 2 x 3-phase 32 A Type 2 open-ended charging cable 5 m with cable holder

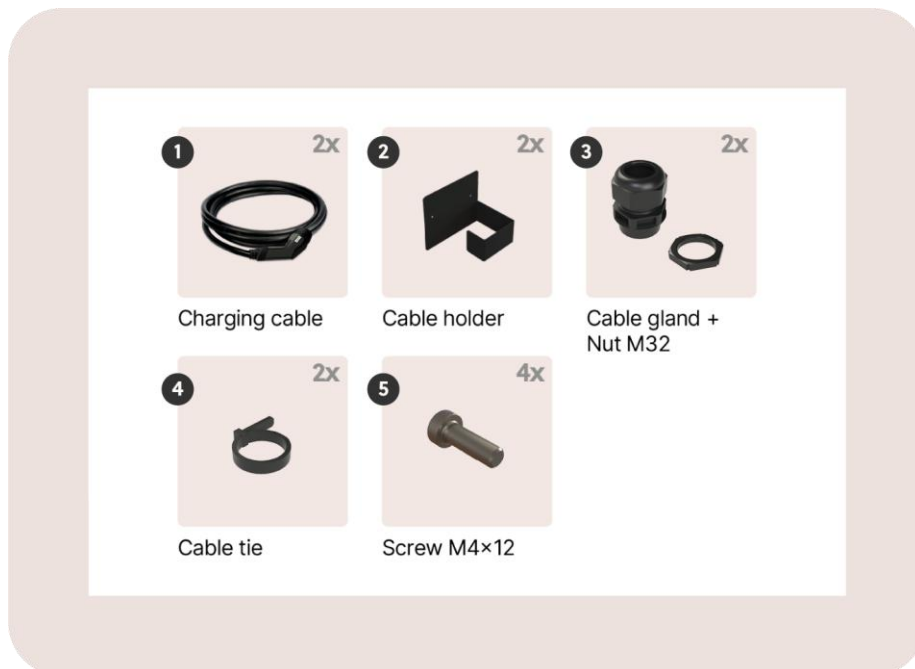



Image 4: Content of the box with the charging cable

ID	Quantity	Description
1	2	Charging cable
2	2	Cable holder
3	2	Cable gland
4	2	Cable tie
5	4	Screw M4x12

Box with the charging cables with shutter for the EV Dual Base

4  Identification stickers on the box

[EVD-FLOOR-2CS8] EV Dual Base 2 x 3-phase 32 A Type 2 with shutter open-ended charging cable 8m with cable holder

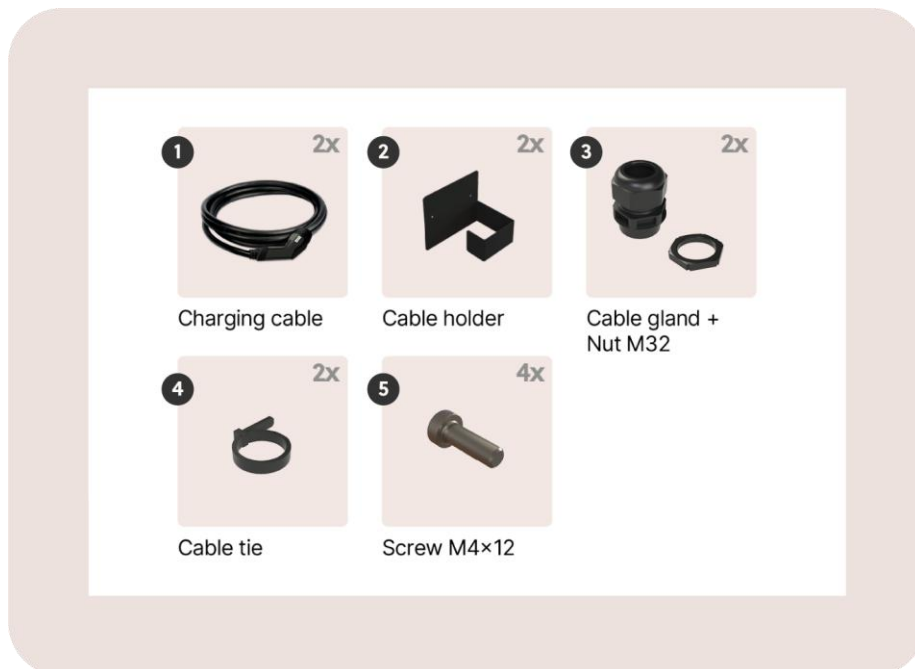

Image 5: Content of the box with the charging cable with shutter

ID	Quantity	Description
1	2	Charging cable with shutter
2	2	Cable holder
3	2	Cable gland
4	2	Cable tie
5	4	Screw M4x12

Box with the plates for the EV Dual Wall

2 Identification stickers on the box



NOTE

Variants per colour:

[EVD-WALL-KIT-B] EV Dual Wall plate kit Black

[EVD-WALL-KIT-W] EV Dual Wall plate kit White

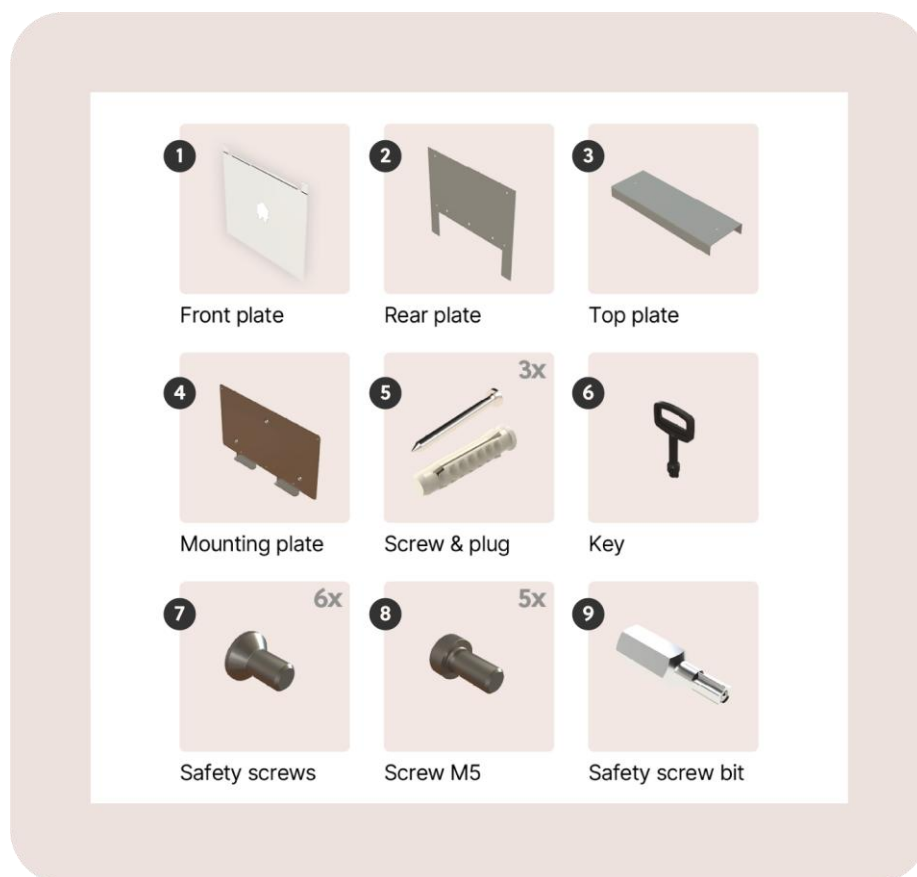



Image 6: Content of the box with the plates

ID	Quantity	Description
1	1	Front plate
2	1	Rear plate
3	1	Top plate
4	1	Mounting plate
5	3	Screw & plug
6	1	Key
7	6	Safety screws
8	5	Screw M5
9	1	Safety screw bit

Box with the charging cables for the EV Dual Wall

3  Identification stickers on the box

[EVD-WALL-2C5] EV Dual Wall 2 x 3-phase 32 A Type 2 open-ended charging cable 5 m with cable holder



Image 7: Content of the box with the charging cable

ID	Quantity	Description
1	2	Charging cable
2	2	Cable holder
3	2	Cable tie
4	4	Screw & plug

Box with the charging cables with shutter for the EV Dual Wall

3  Identification stickers on the box

[EVD-WALL-2CS8] EV Dual Wall 2 x 3-phase 32 A Type 2 with shutter open-ended charging cable 8 m with cable holder

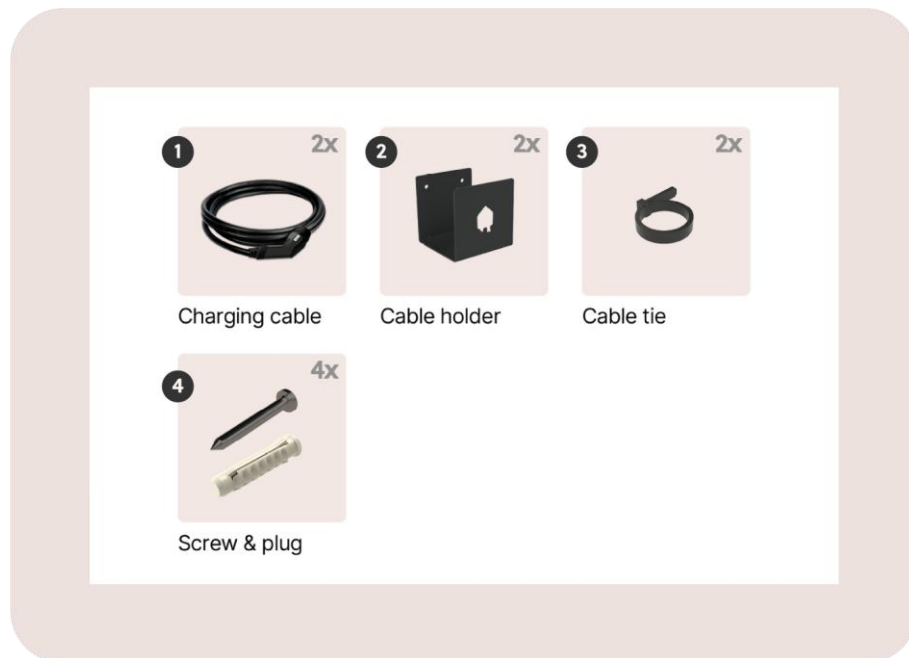

Image 8: Content of the box with the charging cable with shutter

ID	Quantity	Description
1	2	Charging cable with shutter
2	2	Cable holder
3	2	Cable tie
4	4	Screw & plug

3.3 Directional determination

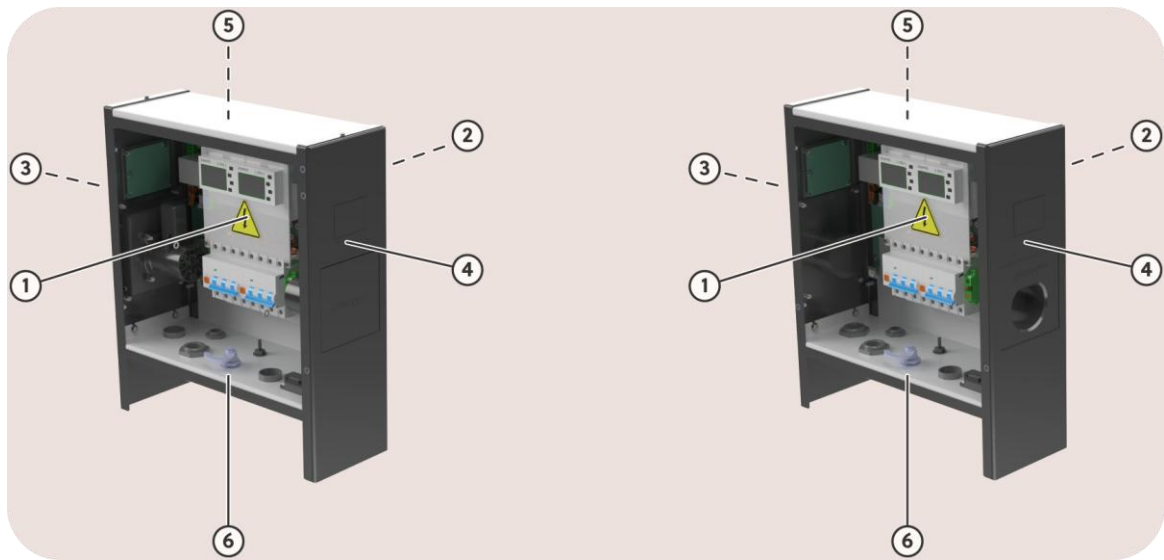

Image 9: Directional determination for a cable and socket model

Id	Description
1	Front
2	Rear
3	Connector 1
4	Connector 2
5	Top
6	Bottom

3.4 Identification label of the EV Dual

Position of the identification label of the EV Dual

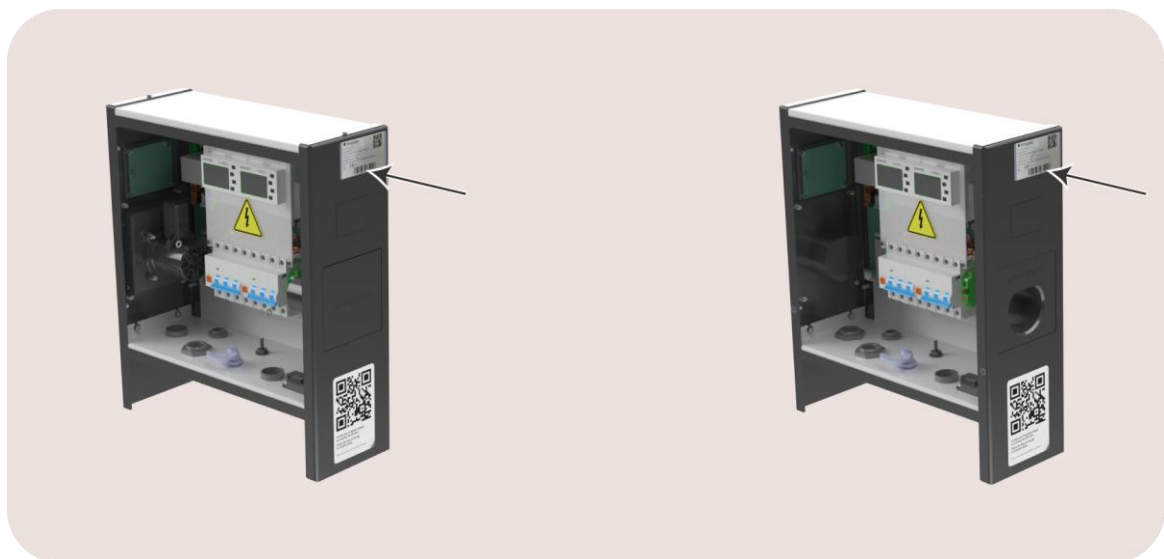

Image 10: Position of the identification label

Identification label of the EV Dual



Image 11: Identification label

No.	Description
1	Manufacturer
2	Article number
3	Serial number
4	Electrical rating
5	Operating temperature
6	Manufacturing date
7	Manufacturer address
8	Waste disposal symbol
9	CE
10	Ingress protection rating
11	EAN-code
12	QR code to scan during configuration of the charging station

3.5 Technical specifications

Feature	Description	
	EV Dual Wall	EV Dual Base
Physical properties		
Dimensions	450 mm x 450 mm x 150 mm	1200 mm x 600 mm x 150 mm
Weight	Charging station with sockets: 16.6 kg Charging station with cables: 22.3 kg Charging station with shutter cables: 24.4 kg	Charging station with sockets: 40.7 kg Charging station with cables: 45.7 kg Charging station with shutter cables: 47.8 kg
Socket	2 x IEC 62196-2 Type 2 with integrated shutter Electronic lock of socket can be locked permanently by the user.	
Charging cable	2 x IEC 62196-2 Type 2 charging cable 5 m (usable length: 4 m) or 2 x IEC 62196-2 Type 2 charging cable with shutter 8 m (usable length: 7 m)	
Stationary / moveable	Fixed installation	
External design	Enclosed assembly	
Mounting method	Wall mounted	Ground mounted
Technical features		
Maximum nominal power per connector	Single-phase connection: 7.4 kW Three-phase connection: 22 kW	
Charge mode	Mode 3 (IEC 61851)	
Connection case	Case A and B (Socket) (IEC 61851)	
	Case C (Fixed cable) (IEC 61851)	
Metering	MID certified class B	
Integrated Residual Current Protection	Rated operating residual current detection: 6 mA DC RCM and 30 mA C40 AC RCBO Type A 10 kA	
Required external circuit breakers	1 x power supply: 1 x 2P (single-phase), 1 x 3P (three-phase) or 1 x 4P (three-phase with neutral) breaker of max 80 A, type B or C (with internal use of busbar) 2 x power supply: 2 x 2P (single-phase), 2 x 3P (three-phase) or 2 x 4P (three-phase with neutral) breaker of maximum 40 A, type B or C	
Power supply line connection	Flexible conductors up to 16 mm ² or solid conductors up to 25 mm ² and power supply cable outer diameter range Ø 13 to 21 mm	
Supported power systems	TN-C, TN-C-S, TT, IT ¹	
Grounding	TN system: PE wire TT system: Independently installed ground electrode < 100 Ohm spreading resistance	

¹ Caution: not all electric vehicles support the IT system. For 3 x 230 V charging, a voltage transformer might be necessary.

Feature	Description	
	EV Dual Wall	EV Dual Base
	IT system: connected to a shared reference (common earth) with other metal parts	
Rated voltage (UN)	230/400 VAC	
Rated insulation voltage (Ui) of a circuit	500 V	
Rated impulse withstand voltage (Uimp)	Overvoltage Category III (4 kV)	
Rated frequency (fN)	50 Hz / 60 Hz	
Rated current (Ina)	32 A	
Rated current (Inc) of a circuit	32 A	
Rated peak withstand current (Ipk)	10 kA	
Rated conditional short-circuit current (Icc)	10 kA	
EMC classification	Class B	
Connection method	AC, permanently connected	
Interfaces & Connectivity		
Information status	2.77" LCD screen	
Session activation	unauthenticated, Swipe RFID, Scan QR code, optional Pay Station	
Connectivity	Ethernet 100BASE-T, 4G LTE-M ²	
Communication protocol	ISO 15118 V2G, OCPP 1.6 JSON, ready for update to OCPP 2.0.1	
Certifications and Standards		
Product certification	CE	
Standards	Safety: EN IEC 61851-1, EN IEC 62311 EMC: EN IEC 61851-21-2, EN ETSI 301 489-1, EN ETSI 301 489-17, EN ETSI 301 489-52 Radio spectrum: EN ETSI 300 220, EN ETSI 300 328, EN ETSI 301 908-13	
Environment		
Enclosure material	Aluminium (front plate), Magnelis (structure)	Magnelis
Enclosure standard colours	RAL 9016 (star white), RAL 7021 (black grey)	
Protection degree	IP54	
Mechanical impact protection	IK10	
Pollution degree	3	
Electrical safety class	I	

² A complimentary five-year period of 4G connectivity (LTE) is included. Following this initial term, an integrated 4G service (LTE) for 1 year, with yearly renewal, is offered.

Feature	Description	
	EV Dual Wall	EV Dual Base
Stand-by use	LED brightness 0%: 3 W LED brightness 100%: 18 W	LED brightness 0%: 3 W LED brightness 100%: 18 W
Environmental conditions	Indoor and outdoor use	
Operating temperature	-25 °C to 40 °EV	
Storage temperature	-25 °C to 60 °C	
Relative humidity	0 % to 95 %, non-condensing	
Maximum installation altitude	0 – 2.000 m	
Access	Locations with restricted and non-restricted access	
Theft protection	Lock and key + safety screws	Safety screws

NOTE



- The operating temperature assumes the ambient temperature of a product delivered in the default enclosure colour RAL 9016 (star white) or RAL 7021 (black grey). Direct exposure to sunlight may have an adverse effect on the temperature range.
- If the product is exposed to lower or higher ambient temperatures, continuous operation cannot be guaranteed. If temperatures exceed the maximum values, the charging station will automatically decrease the charging current to decrease the internal temperature of the charging station. This stabilises the internal temperature and makes it less likely that a charging session will be unexpectedly paused.
- If the product is directly exposed to sunlight, the automated temperature management may automatically start below the maximum ambient temperature. Therefore, wherever possible, avoid exposing the charging station to direct sunlight.
- Where products are exposed to the elements of nature, the enclosure can be subject to gradual aging of the material, which can result in product discolouration over time. Therefore, wherever possible, place the product in a sheltered place to optimise the life of the materials.

4 Prepare the installation

For overload protection or optimised self-sufficiency, additional Smappee Infinity components must be installed to measure the Grid and Solar, Battery or other submetering if applicable.



NOTE

For more information, refer to the [Smappee Academy](#).

The first step is to prepare the physical installation of the EV Dual as described in this chapter.

4.1 Installation prerequisites

- Obtain all necessary permits from the relevant local authorities.
- Local regulations may be applicable and can vary depending upon the region or country.
- Make sure that there is sufficient space around the charging station as specified in the IEC 60204-1 standard.
- Make sure that the installation area of the charging station is adequate for usability and ventilation purposes.
- Refer to local wiring regulations to select the conductor sizes and use only copper conductors.
- Calculate the existing electrical load to find the maximum operating current for the charging station installation.
- The appropriate wire gauge of the supply cable depends on the power rating and distance between the meter cabinet and the charging station. The voltage drop must not exceed 5 %. It is advisable to have a maximum voltage drop of 3 %.
- The power supply connection must be protected against short-circuiting and over-current with an individual circuit breaker. This circuit breaker must be 2-pole (for single-phase), 3-pole (three-phase without neutral) or 4-pole (three-phase with neutral), curve B or C, and have a current rating of maximum 80 A for 1 power supply cable for the 2 connectors, or maximum 40 A if each connector is directly connected to a power supply cable (or otherwise in compliance with local standards and regulations). You can also use circuit power supply with a applicable circuit breaker for the total load.



NOTE

Some EVs are not compatible with a 3 x 230 V grid due to a built-in security in the EV. Contact your EV manufacturer for more information. If your EV is not compatible with this grid topology, or if you would like to achieve higher charging power than what is possible on a delta grid topology, you can install a transformer that converts the 3 x 230 V topology to a standard 3 x 400 V + N topology.

- Make sure that there is one network cable for the internet connection available for each EV Dual. If you want to, you can daisy-chain up to 5 EV Duals. For more information, refer to Connect the network cable (page 45).

- Route each power supply cable and the network cable, if applicable, to the position where the charging station will be installed.

	<p>NOTE</p> <p>To be able to connect the EV Dual easily, make sure that there is at least:</p> <ul style="list-style-type: none">• 1.3 m (4.27 ft) power supply and 1.3 m (4.27 ft) network cable length available at the location of the EV Dual Base• 0.30 m (1 ft) power supply and 0.30 m (1 ft) network cable length available at the location of the EV Dual Wall
---	---

- Use the supplied mounting plate (page 26) to attach the EV Dual.

4.2 Tools (not included)

- Torque wrench with extension bar and socket (PZ2, T20H, inner hex 2.5 and 4 mm and screw width 10 and 19 mm)
- Key SW7 and SW14
- Wire stripper and cutter
- Needle-nose pliers
- Ferrules crimper (only for stranded power supply cables)
- RJ45 crimping tool
- Rock drill diameter 12 mm (floorplate) or 10 mm (wall mounting plate)
- Hammer

4.3 Supplies (not included)

- Circuit breaker and cable for each power supply
- Network cable and RJ45 connectors, minimum Cat 5 depending on the environment
- Ferrules, when using stranded power supply cables or decreasing the length of the charging cable
- Cable ties to attach cables to the LED holder of an EV Dual Base

4.4 Prepare the installation of the EV Dual Base



NOTE

This section is only relevant if you install a ground mounted model of the EV Dual. For a wall mounted EV Dual, go to Prepare the installation of the EV Dual Wall (page 35).

Prepare the foundation

Context

A stable and level ground needs to be prepared in advance and there must be one or two power supply cables and one network cable. The surface of the ground must be solid to allow the usage of concrete anchors and avoid moisture from the soil.

We recommend a levelled concrete foundation at ground level. This can be a polished concrete floor in a parking garage or a flat surface for installation of the charging stations.

If you want a foundation for each EV Dual, you should do the following.

Instructions

Proceed as follows.

1. Make a foundation hole that is large enough.
Depending on the subsoil, the size may vary. Please refer to the technical specifications of size and weight to determine and construct a solid foundation for the EV Dual.
When dimensioning the foundation, it is advisable to carry out a static load capacity analysis according to the relevant standards.

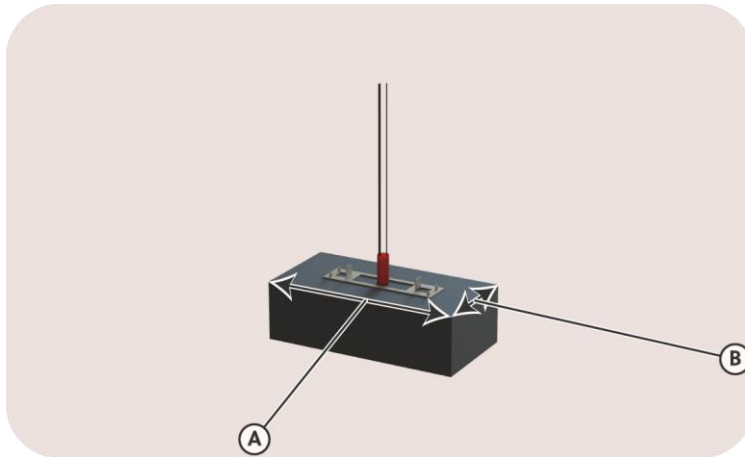

Image 12: View on the minimum dimensions: $A \times B = 0.80 \text{ m} \times 0.35 \text{ m}$ or $2.62 \text{ ft} \times 1.15 \text{ ft}$

2. Route each power supply cable and one network cable to the location of the EV Dual.

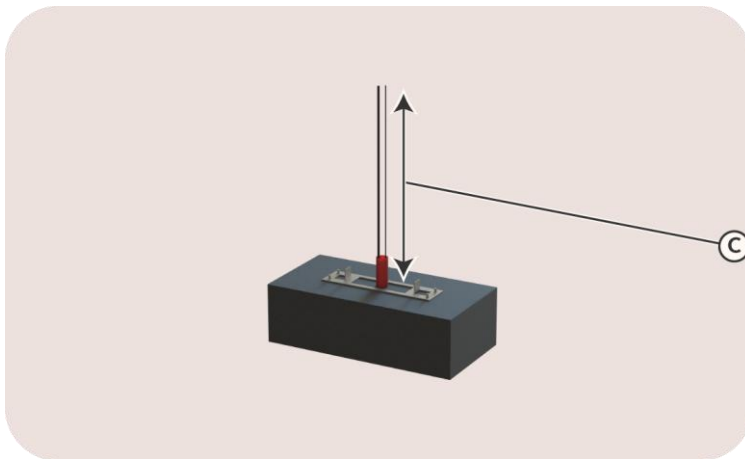

Image 13: View on the necessary cable length (C = 1.3 m or 4.27 ft)

3. Fill foundation hole with concrete.

Wait for the concrete to cure before going to the next steps.

Install the floorplate

Proceed as follows.

1. Put the floorplate on the prepared location.
Route each power supply cable and one network cable through the central opening of the floorplate.
2. Drill four 12 mm holes to a depth of 75 mm.

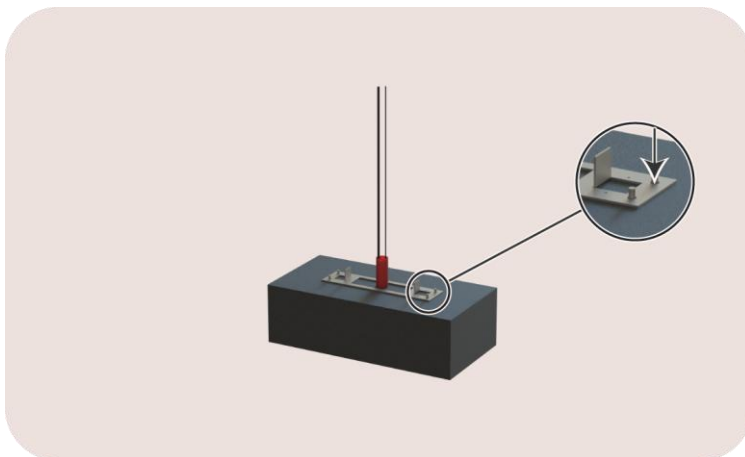

Image 14: View on the floorplate, with installed concrete anchors.

3. Put a concrete anchor in each hole.
You can chemically anchor this.
Make sure that there is approximately 3 cm of threaded wire visible above ground level.
Make sure the floorplate is level in both directions.
4. Keep the washers and nuts.
For more information, refer to Attach the pedestal to the floorplate (page 29).

Assemble the pedestal

Instructions

Proceed as follows.

1. Attach the side brackets to the cross beam.
Use a torque wrench with bit H2.5 and a key SW7 to tighten each bolted connection to a torque of 2.5 Nm.



Image 15: View on the cross beam (A) and side brackets (B)

2. For a cable variant:
 - Attach the cable holders.
Use a torque wrench with bit H2.5 to tighten each bolted connection to a torque of 2.5 Nm.
 - Put a cable gland in each cable entry.
Tighten by hand so that the charging cable can go through.

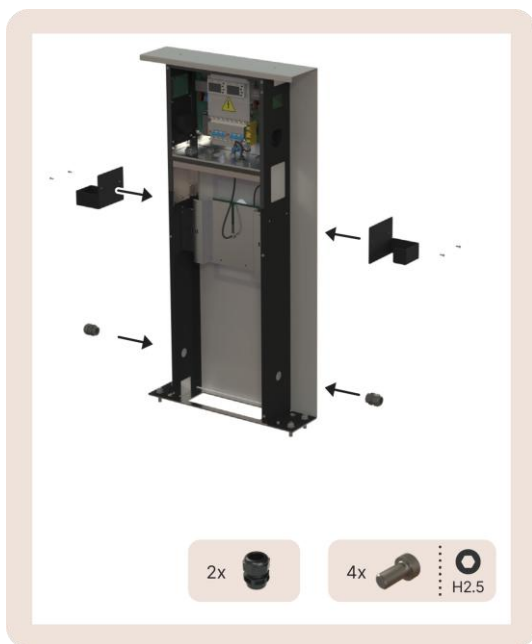

Image 16: View on the pedestal (A), cable holders (B) and cable glands (C)

3. For a socket variant, close the cable entries with the plugs.

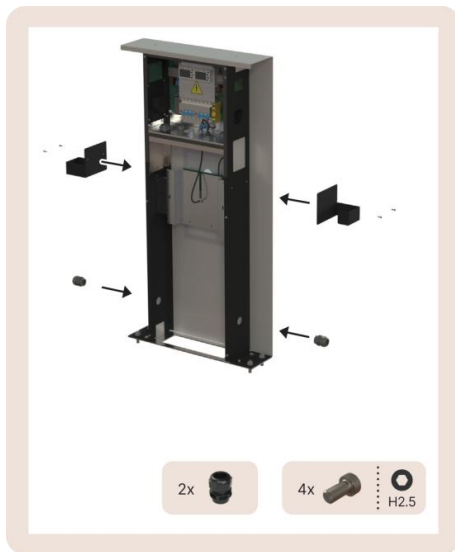

Image 17: View on the pedestal (A) and plugs (B)

Attach the pedestal to the floorplate

Context

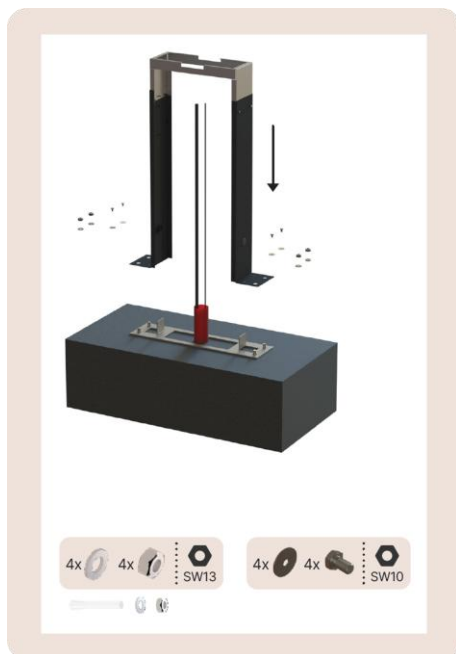

Image 18: View on the pedestal (A) and the foundation (B)

Instructions

Proceed as follows.

1. Move the pedestal over the threaded rods.
2. Attach the pedestal to the floorplate.
Use a torque wrench with bit SW10 to tighten each bolted connection to a torque of 5 Nm.
3. Put a washer and nut over each threaded rod.
For more information, refer to Prepare the foundation (page 26).
4. Attach the assembly to the foundation.

Use a torque wrench with bit SW13 to tighten each bolted connection to a torque of 15 Nm.

Attach the core to the pedestal

Move the core over the pedestal.



Image 19: View on the pedestal (A) andh the core (B)



NOTE

The core is attached to the pedestal with the front plate and rear plate. For more information, refer to Complete the installation of the EV Dual Base (page 48).

Attach the LED holder to the pedestal

Context



Image 20: View on the pedestal (A) and the LED holder (B)

Instructions

Proceed as follows.

1. Move the LED holder between the side beams.
2. Attach the LED holder to the pedestal.
Use a torque wrench with bit SW7 to tighten each bolted connection to a torque of 2.5 Nm.

Attach the antenna to the LED holder

Context



Image 21: View on the antenna removal (A) and attachment to the LED holder (B)

Instructions

Proceed as follows.

1. Remove the LED holder between the side beams.
Loosen the nut SW14, refer to image A.
2. Move the antenna in the slot of the LED holder.
Tighten by hand.
3. Put a plug in the opening of the EV Dual Core.

Connect the cable to the LED board

Context

The contact on the core is only used for the front plate of an EV Dual Wall.

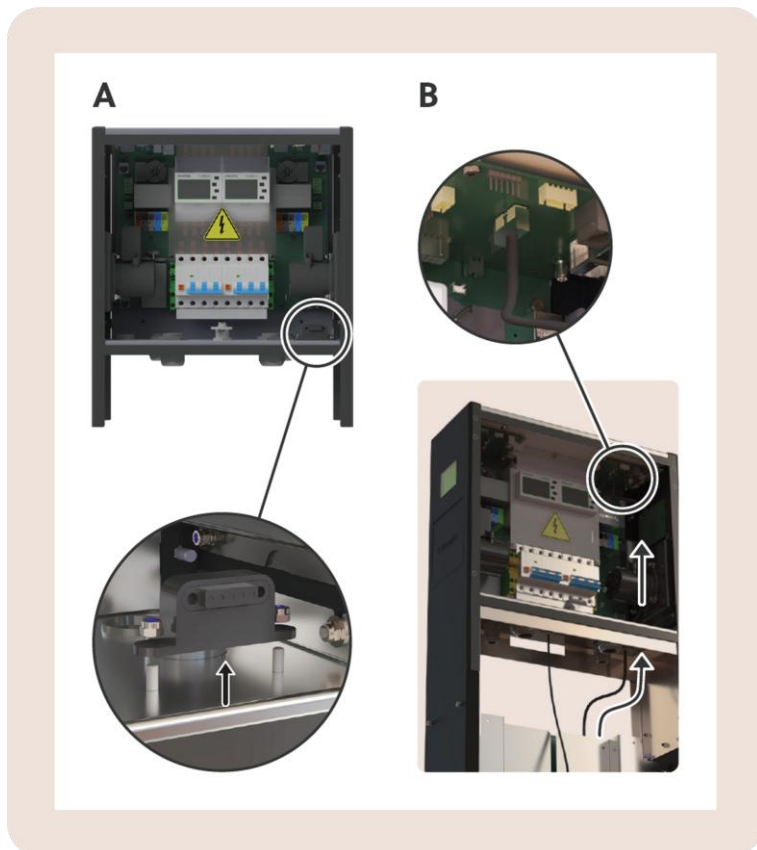

Image 22: View on the contact removal (A) and cable connection (B)

Instructions

Proceed as follows.

1. Loosen the nuts SW7.
2. Remove the contact.
3. Guide the cable through the grommet.



Image 23: View on the grommet (D) for the cable to the LED board.

4. Connect the cable to the terminal marked with LED.

Attach the plates to EV Dual Base

Context

The top plate is attached to the core. The front plate and the rear plate are also attached to the pedestal. For maintenance, only the rear plate needs to be removed.

Instructions

Proceed as follows.

1. Attach the top plate with 2 screws and the front plate with 6 screws.



Image 24: View on the top plate (A) and front plate (B)

2. Tighten the screws.
Use a torque wrench with bit T20H to tighten to a torque of 2.5 Nm.

As a result, the EV Dual Base is ready for installation and configuration. Go to page 39.

4.5 Prepare the installation of the EV Dual Wall



NOTE

This section is only relevant if you install a wall mounted model of the EV Dual. For a ground mounted EV Dual, go to Prepare the installation of the EV Dual Base (page 26).

Install the wall mounting plate

Context

The wall mounting plate lets you smoothly attach the charging station to a wall.



Image 25: View on the wall mounting plate (A) and a spirit level (B)

Instructions

Proceed as follows.

1. Put the mounting plate on the position where the EV Dual will be installed.
Make sure the two supports of the mounting plate point down.
Use a spirit level to make sure the mounting plate is level.
2. Use the mounting plate to mark the position of the screws on the wall.
3. Drill three 10 mm holes to a depth of 70 mm.
4. Insert the supplied wall plugs into the holes.
5. Attach the mounting plate with the supplied screws.

Attach the plates to the EV Dual Core

Context



Image 26: View on the top plate (A) and rear plate (B)

Instructions

Proceed as follows.

1. Attach the top plate with 2 screws and the rear plate with 4 screws.
2. Tighten the screws.
Use a torque wrench with bit T20H to tighten to a torque of 2.5 Nm.

As a result, the EV Dual Core is prepared for the next step.

Attach the Core to the wall mounting plate

Context



Image 27: View on the wall mounting plate (A) and the EV Dual Core (B)

Instructions

Proceed as follows.

1. Position the EV Dual Core in front of the mounting plate.
2. Attach the EV Dual Core to the mounting plate.
Use the three M4 x 6 mm hex screws.

As a result, the EV Dual Wall is ready for installation and configuration.

Attach the cable holders



NOTE

This section is only relevant if you install a cable model of the EV Dual. For a socket model of the EV Dual, go to Installation and configuration (page 39).

Context

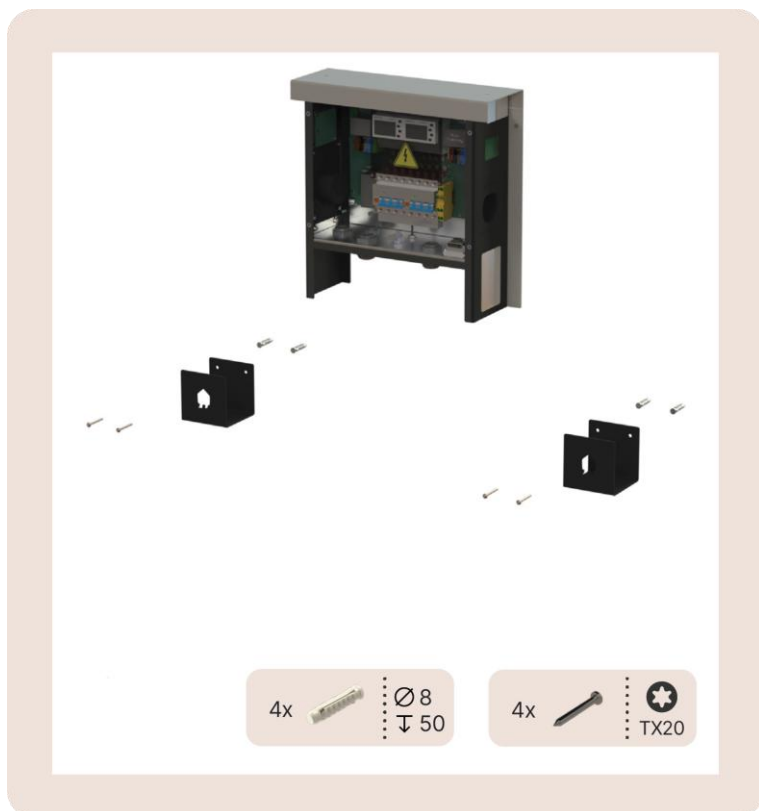

Image 28: View on the EV Dual Core (A) and the cable holders (B)

Instructions

1. Put a cable holder in a spot where there is space to store the rolled-up charging cable. Make sure the cable holder is level.
2. Use the cable holder to mark the position of the screws on the wall. Make sure the two cable holders will be at the same height.
3. Drill four 8 mm holes to a depth of 50 mm.
4. Insert the supplied wall plugs into the holes.
5. Attach the cable holders with the supplied screws.

5 Installation and configuration



CAUTION

The installation must be carried out by a qualified professional who has read this manual and works in compliance with local and national standards. Neglecting this may lead to severe injuries or hazardous situations while working with electricity.



CAUTION

The electric system must be entirely disconnected from every power source prior to performing installation or maintenance work. Make sure it is not possible to connect the electric current during installation. Put up caution tape and warning signs to mark the work areas. Make sure no unauthorised people can enter the work areas.



CAUTION

The charging station contains electric components that may still contain electrical charge after being disconnected. Wait at least 10 seconds after disconnection before commencing work.



CAUTION

Adaptors or conversion adaptors and cord extension sets are not allowed to be used.

This procedure describes the required steps for the physical installation of the EV Dual.

1. Connect the power supply (page 40)
2. Connect the charging cable (page 43)
3. Connect the network cable (page 45)
4. Complete the installation (page 48)

After the physical installation, the configuration can be done. For more information, refer to:

5. Configure the EV Dual with the Smappee App (page 49)
6. Give the owner a smooth start (page 50)

5.1 Connect the power supply

Prerequisites

Each EV Dual has two MID meters that each measure the power supplied to the connector. No other components must be installed to measure the charging station consumption.

Each power supply cable must have its own circuit breaker.



CAUTION

If you use two power supply cables, remove the comb busbar. This comb busbar is installed for use of one power supply cable. For more information, refer to the middle detailed view on Image 31 (page 41).

It is possible to branch off the power supply from a circuit power supply.

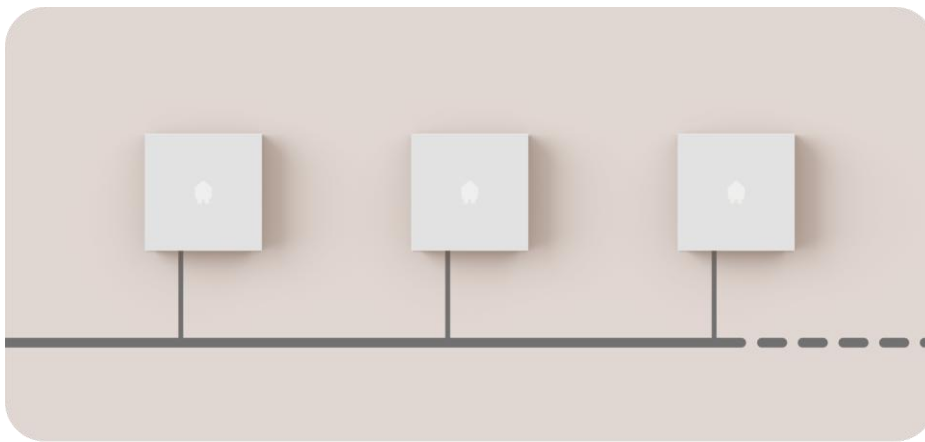

Image 29: View on the optional circuit power supply

For more information, refer to Installation prerequisites (page 24).

Instructions

1. Guide each power supply cable through the cable gland in the middle of the EV Dual.

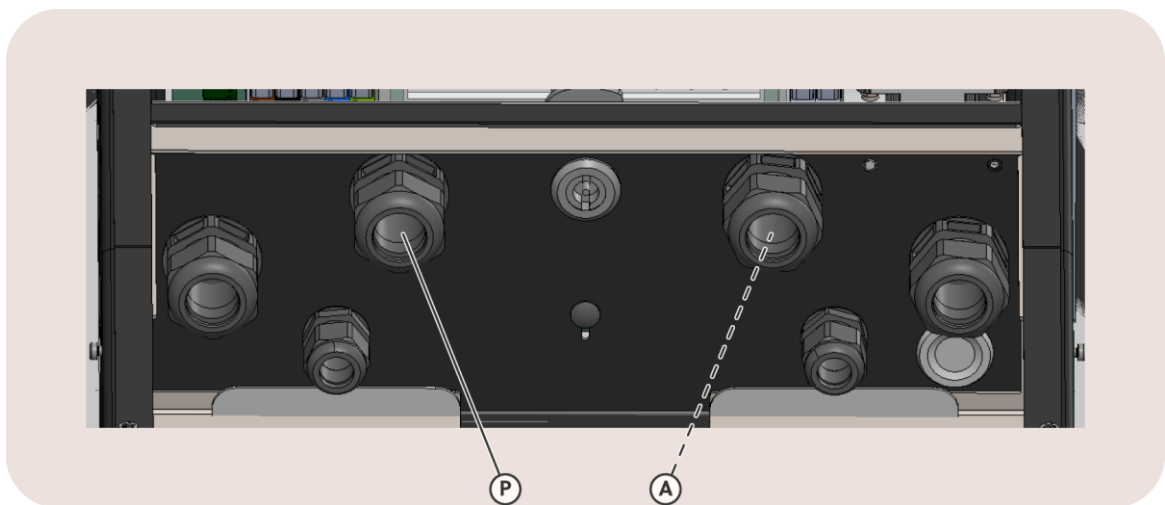

Image 30: View on the cable glands for power supply (P) and optional second power supply (A).

2. Tighten the cable gland.

- Cut each power supply cable to the sufficient length.
For stranded wires, add a wire end ferrule to each conductor.
- Connect the power supply wires as follows:

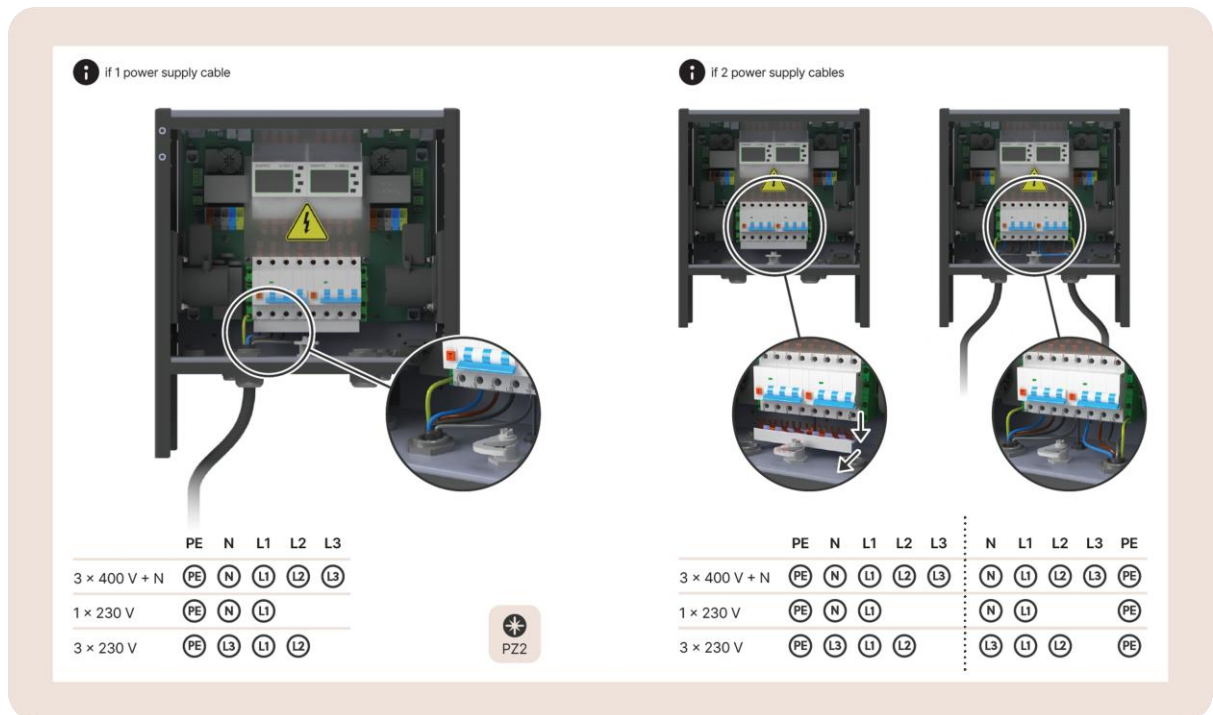

Image 31: View on the power supply connection for 1 or 2 power supply cables

- Put the green/yellow conductor in the corresponding terminal block for the protective earth (PE).
- Put the blue conductor, if applicable, in the corresponding connection point for the neutral (N) of the residual current device.



NOTE

For a 3 x 230 V with a transformer, the neutral conductor comes from the transformer.

- Put the phase conductors in the necessary connection point of the residual current device.



NOTE

- L1 = brown phase 1-conductor
 - L2 = black phase 2-conductor, if applicable
 - L3 = grey phase 3-conductor, if applicable
- For a 3 x 230 V without a transformer, and thus no neutral conductor, put the grey conductor in the neutral connection point.



NOTE

If you install more than 1 charging station on a 3 x 400 V + N grid, we recommend different connection of the three phases. For more information, refer to Phase rotation (page 51).

- For the ground mounted variant, attach each power cable to the LED holder with a cable tie.

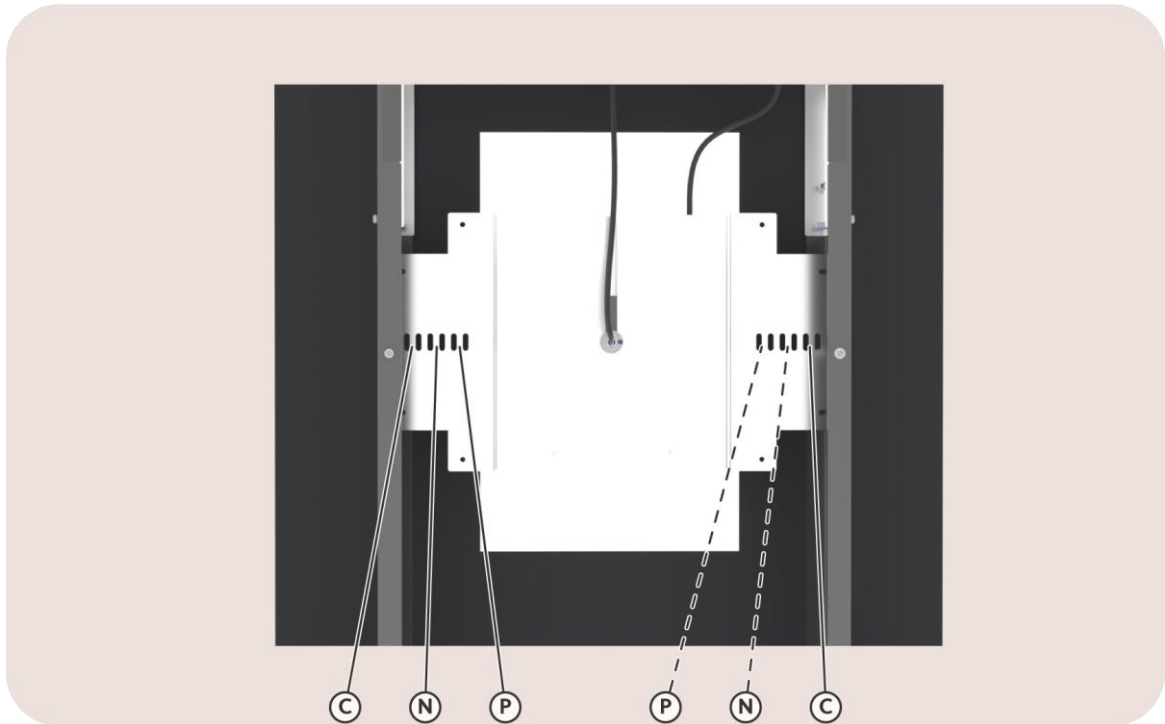

Image 32: View on the attachment of the power supply cable (P), charging cable (C) and network cable (N)

6. Make sure that each residual current device is set to the on position.
As a result, the EV Dual is almost ready for power.

5.2 Connect the charging cables

Context



NOTE

This section is only relevant if you install a cable model of the EV Dual. For a socket model of the EV Dual, go to Connect the network cable (page 45).

The charging cable is delivered in a separate box.

Instructions

Proceed as follows.

1. Guide the power supply cable through an outer cable gland of the EV Dual.



Image 33: View on the cable glands for the charging cables (C).

2. Tighten the cable gland.
3. If necessary, decrease the length of the charging cable.
Add a ferrule (not supplied) on each wire.
4. Connect each wire to the corresponding terminal as indicated with a label.
Do not forget to connect the CP data wire of the charging cable to the CP terminal.

- For strain relief, put the supplied cable tie around the charging cable. Tighten it just after the cable gland on the inside of the charging station.



Image 34: View on the cable connections for a wall mounted and ground mounted EV Dual

- For the ground mounted variant, attach each charging cable to the LED holder with a cable tie.

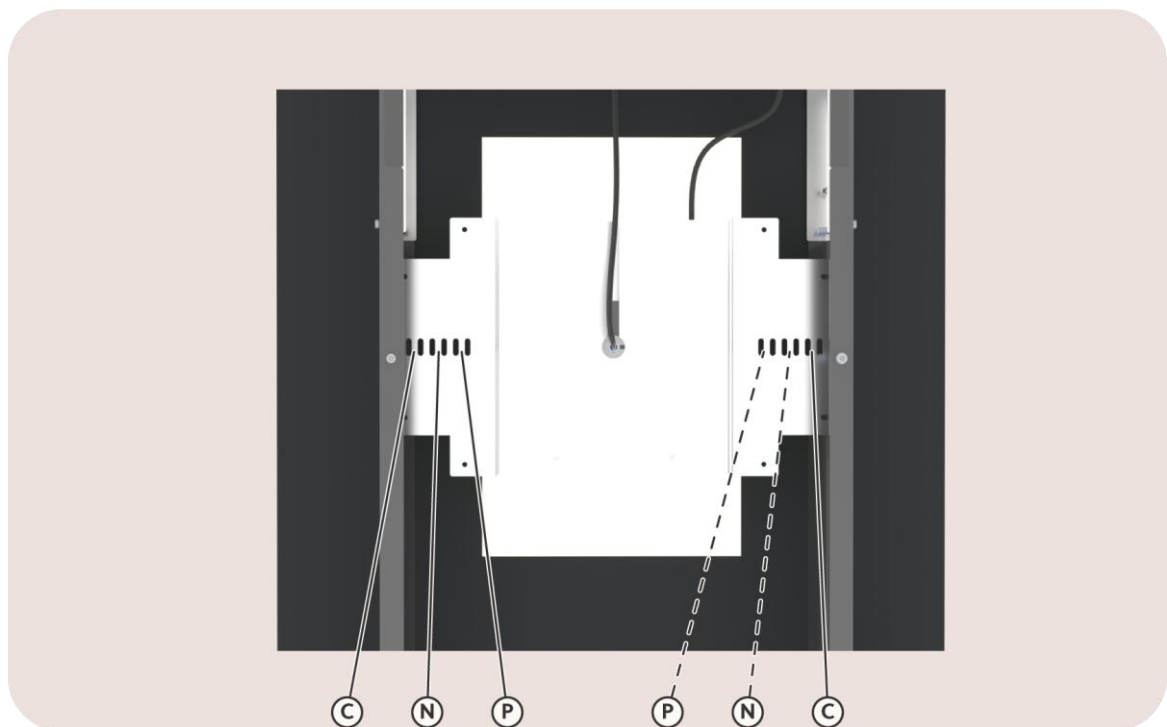

Image 35: View on the attachment of the power supply cable (P), charging cable (C) and network cable (N)

- Repeat steps 1 thru 6 for the charging cable at the other side of the charging station.

5.3 Connect the network cable

Context



NOTE

This section is only relevant if you will use wired internet connection. For other internet connections, go to Complete the installation (page 48).

Communication with the internet can occur in two ways: wired connection (Ethernet) or 4G. In this topic you can read how to do the physical connection of the network cable. The connection will be set up during configuration (page 49).

The network topology can be a star, where all network cables are connected to a central point. It is also possible to daisy-chain up to 5 EV Duals.

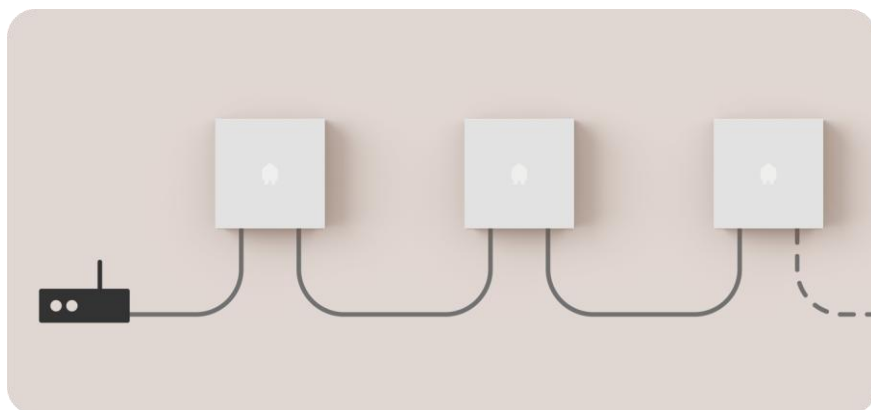

Image 36: View on the optional daisy-chaining

Instructions

Proceed as follows.

1. Guide the network cable through the cable gland (N) at the bottom of the EV Dual.

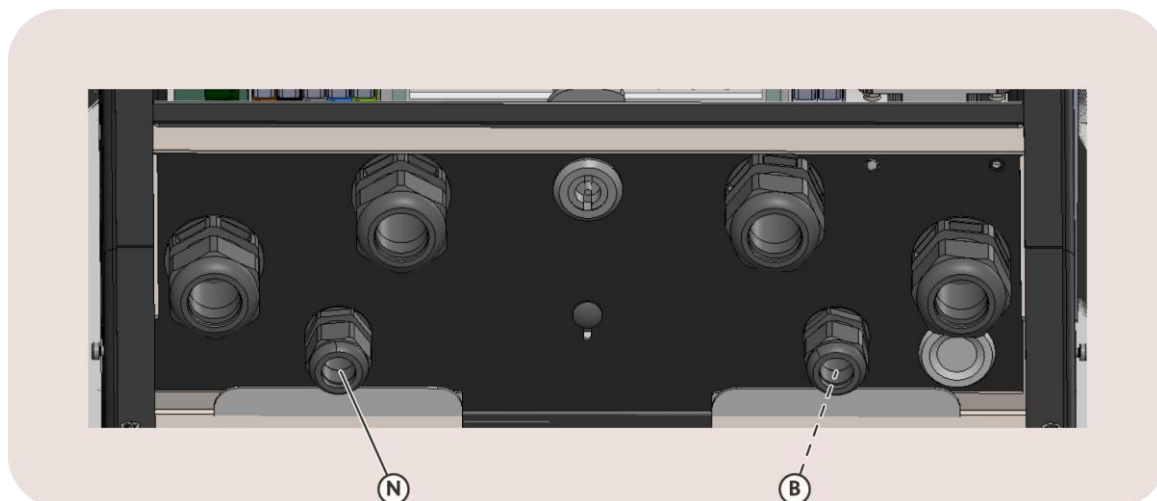

Image 37: View on the cable glands for the network cable (N) and optional cable (B) for daisy-chaining

For a second network cable, replace the plastic plug with a cable gland.

2. Cut the network cable to the necessary length.
3. Attach the RJ45 connector (not supplied).
4. Put the connector in the RJ45 port marked with J7.

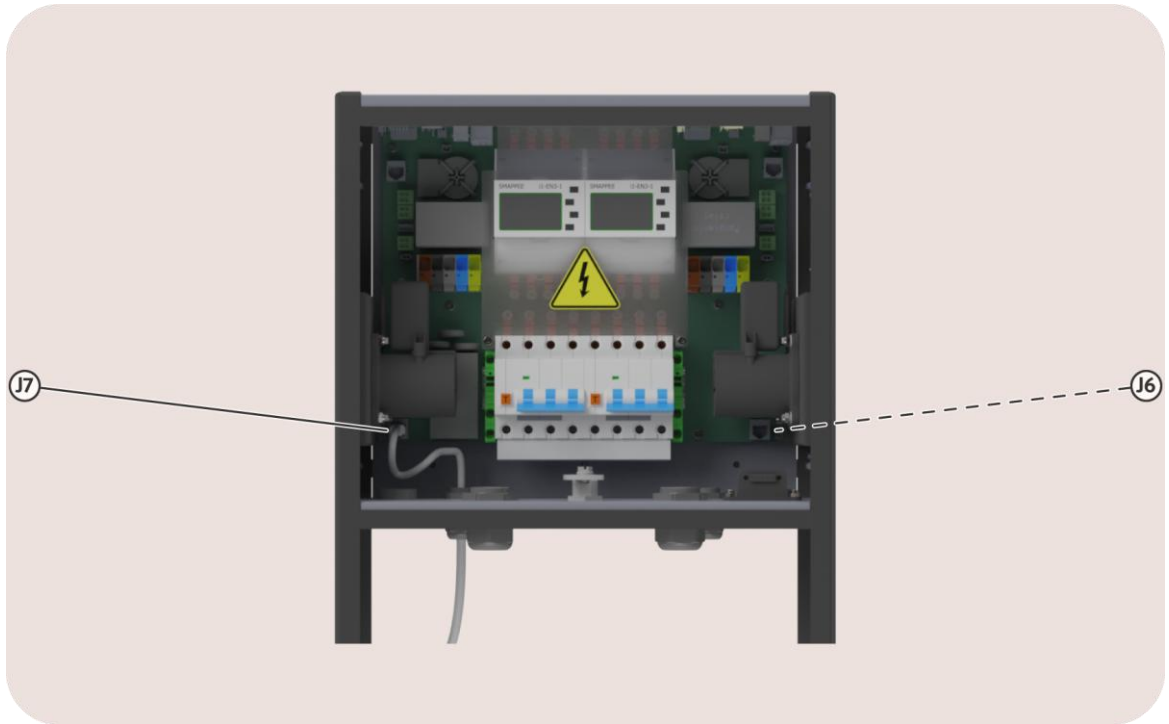

Image 38: View on the port J7 for internet input and the port J6 for optional daisy-chaining

5. Tighten the cable gland.
6. If you want to daisy-chain, repeat the steps 1 thru 5.
7. For the ground mounted variant, attach each network cable to the LED holder with a cable tie.

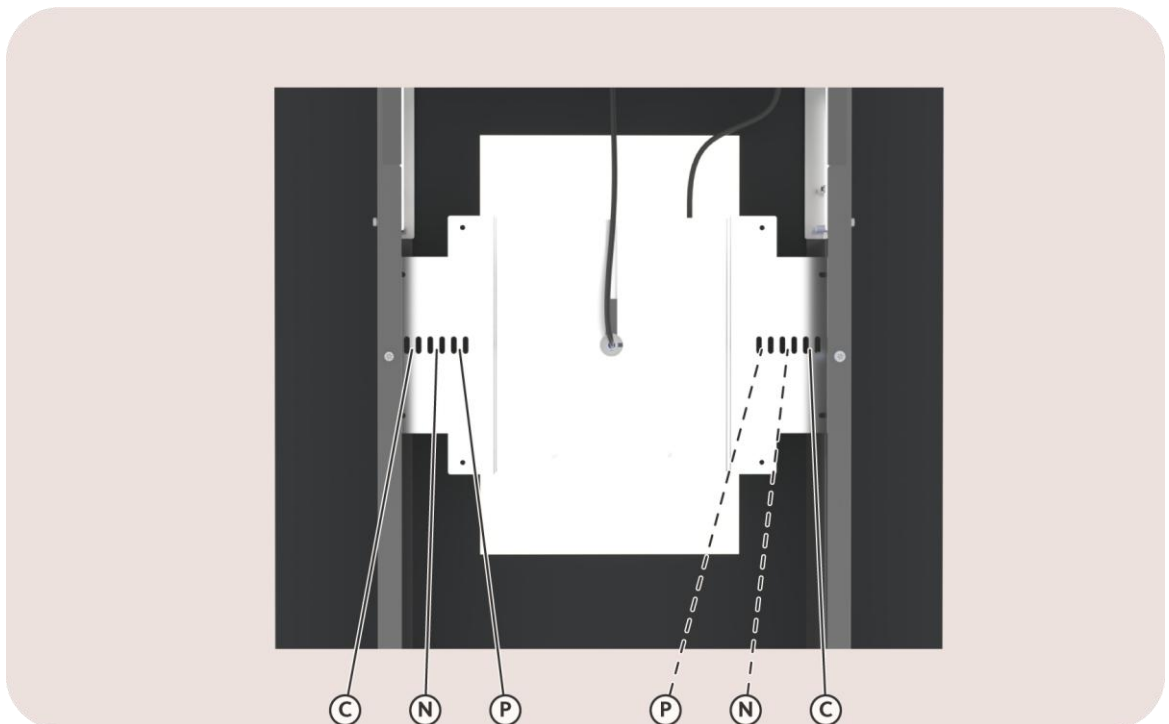

Image 39: View on the attachment of the power supply cable (P), charging cable (C) and network cable (N)

Post-requisites

1. Switch on the power supply to the charging station.
2. Check the status of the components after approximately 30 seconds.

Description	More information
1 x power transformer	Red LED is lighting up in lower corner, side of connector 1
2 x MID meter	Displays are lighting up
2 x charge controller	Green LEDs are blinking in upper corners

3. Switch off the power supply to the charging station.

5.4 Complete the installation

Complete the installation of the EV Dual Base

1. Attach the rear plate with 6 screws.



Image 40: View on the EV Dual Base

2. Tighten the screws.
Use a torque wrench with bit T20H to tighten to a torque of 2.5 Nm.
3. Remove the protective foil from the LCD screens on both sides of the EV Dual.

As a result, the EV Dual is ready for configuration with the Smappee App. Go to page 49.

Complete the installation of the EV Dual Wall

Context

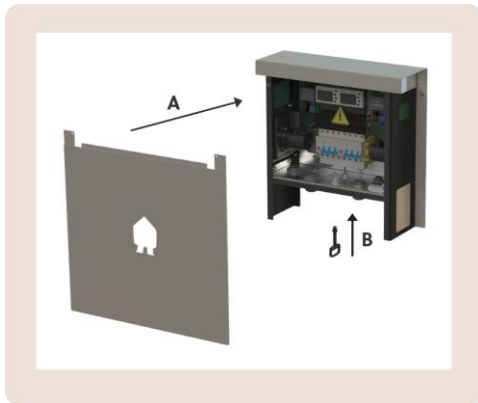

Image 41: View on the EV Dual Wall

Instructions

1. Put the front plate to the EV Dual (A).
2. Close the EV Dual Wall with the key (B).
3. Remove the protective foil from the LCD screens on both sides of the EV Dual.

As a result, the EV Dual is ready for configuration with the Smappee App. Go to page 49.

5.5 Configure the EV Dual with the Smappee App

Instructions

Proceed as follows:

1. Scan the QR code on the side of the charger.

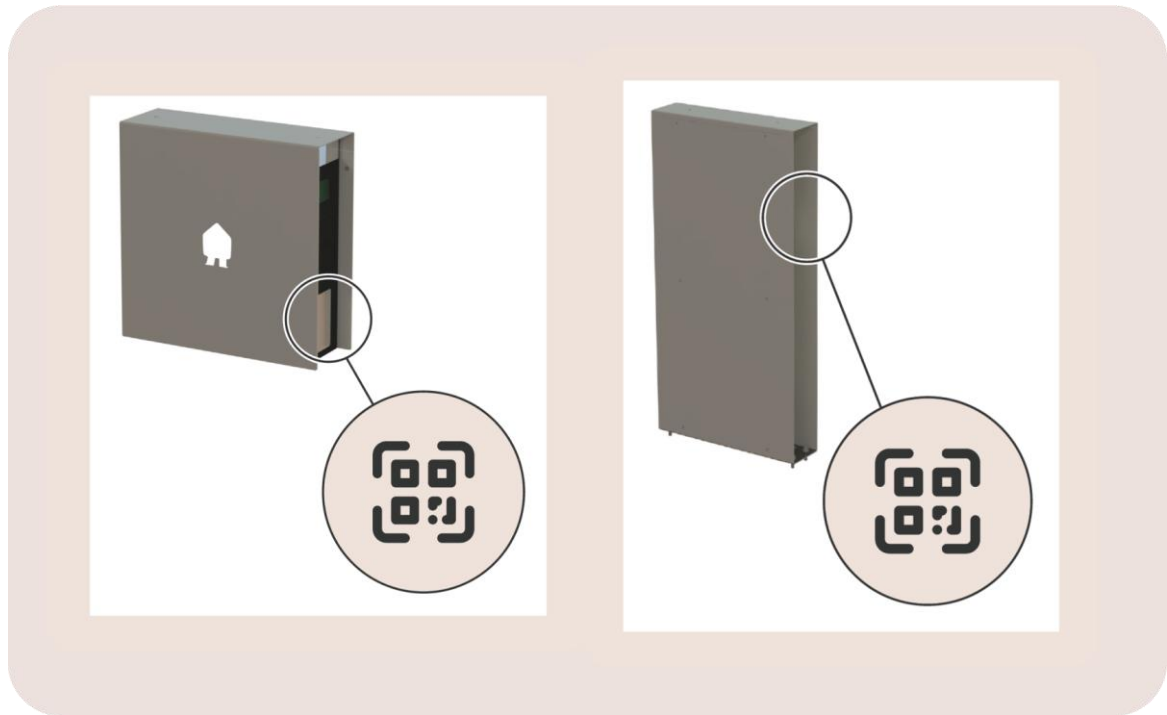

Image 42: QR code on the side of the EV Dual Wall (A) or EV Dual Base (B)

2. Follow the steps in the Smappee App.

Post-requisites

The settings of the charging station can be adjusted in the Smappee App or the Smappee Dashboard.

- Name
- LED brightness
- Maximum current per connector and thus the maximum charging speed per connector

5.6 Give the owner a smooth start

1. Give the Starter kit to the charger owner.
2. Tell them to scan the QR code on the side of connector 2 of the charging station.

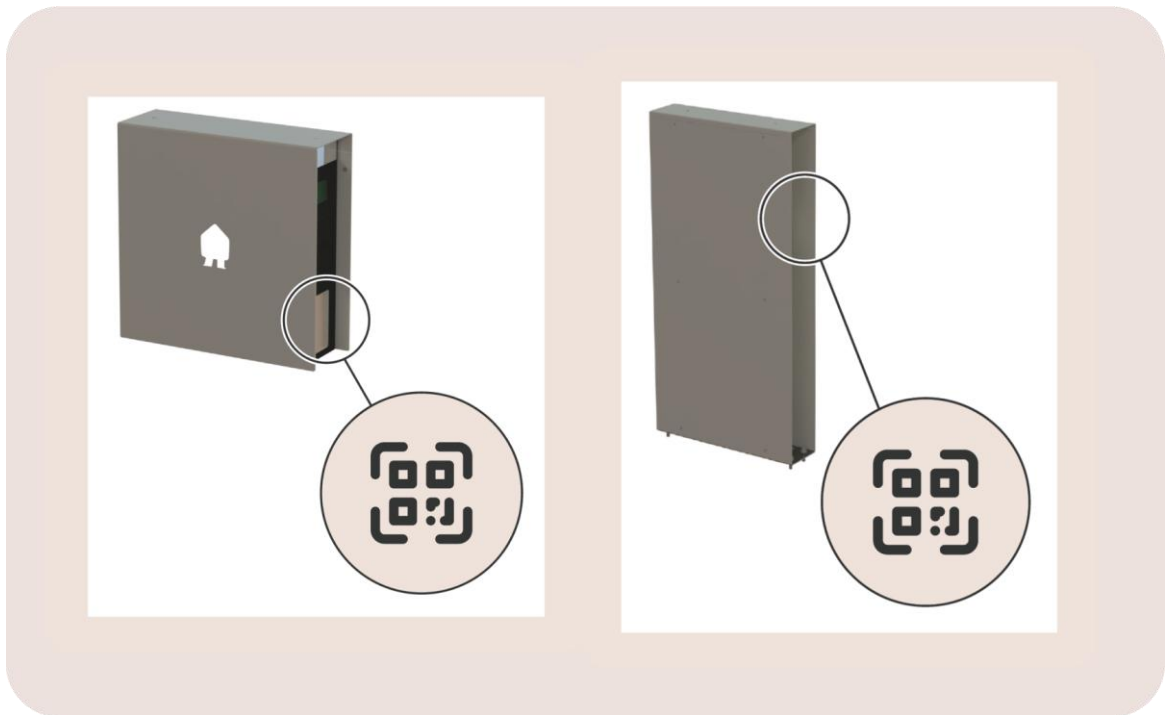

Image 43: QR code on the side of the EV Dual Wall (A) or EV Dual Base (B)

3. Only for EV Dual Wall, give the key of the charging station to the charger owner.

Annexes

Phase rotation

Most of the hybrid vehicles use only one phase for charging.

When connected to a single-phase power supply, the Smappee (Cascade) Overload Protection will control the charging sessions on the L1 phase to prevent a circuit breaker from tripping.

When connected to a three-phase power supply, the Smappee (Cascade) Overload Protection can control the charging sessions on each of the three phases. When charging multiple single-phase electric vehicles at the same time, you can use phase 2 and phase 3 by doing the following:

- During the installation you can do the physical phase rotation.
- During the configuration with the Smappee App you need to set the phase mapping

Example of phase rotation

When you have an EV Dual with 2 power supply cables and an EV One, connect the power supply as indicated with the bold Xs.

Charging stations from the Smappee EV Line		Internal wiring of the phases and their colour in the charging station		3-phase power supply with the colours of the wires to be connected on the position X in the distribution panel		
				3 x 400V + N		
		L1	L2	L3		
		Brown	Black	Grey		
EV Dual connector 1	L1	Brown	X	-	-	
	L2	Black	-	X	-	
	L3	Grey	-	-	X	
EV Dual connector 2	L1	Brown	-	X	-	
	L2	Black	-	-	X	
	L3	Grey	X	-	-	
EV One	L1	Brown	-	-	X	
	L2	Black	X	-	-	
	L3	Grey	-	X	-	

Declaration of conformity

DocuSign Envelope ID: FD7AE8CA-BBBE-8890-8070-428088937215

EU Declaration of Conformity

Manufacturer **Smappee NV**
Address Evolis 104, 8530 Harelbeke, Belgium

Represented by **Stefan Grosjean**
Function CEO

Hereby declares, under the sole responsibility of the manufacturer, that

The product: AC conductive charging equipment

Models: EVDW-2332-Bx, EVDW-2332-C5x, EVDW-2332-CS8x
 EVDB-2332-Bx, EVDB-2332-C5x, EVDB-2332-CS8x
 Where x can be -B (=Black) or -W (=White)

First CE affixed: 2025

Complies with the requirements of the following EU Directives, provided that it is installed, maintained and used according manufacturer's instructions:

2014/53/EU The Radio Equipment Directive

2011/65/EU RoHS Directive

Standards applied:

RED art 3.1.a Health and safety:

EN IEC 61851-1:2019 Electric vehicle conductive charging system - General requirements

EN IEC 62311:2020 Human exposure restrictions for electromagnetic fields (0 Hz to 300 GHz)

RED art 3.1.b Electromagnetic Compatibility:

EN IEC 61851-21-2:2018 EMC requirements for off board electric vehicle charging systems

EN ETSI 301 489-1: 2019 EMC for radio equipment & services: common technical requirements

EN ETSI 301 489-17: 2023 EMC for Broadband and Wideband Data Transmission Systems

EN ETSI 301 489-52: 2024 EMC for Cellular Communication User Equipment

RED art 3.2 Efficient use of Radio Spectrum:

EN ETSI 300 220-1: 2017 Short Range Devices - 25 MHz to 1000 MHz: Technical characteristics

EN ETSI 300 328: 2019 Wideband transmission systems - Data transmission equipment in the 2,4 GHz band

EN ETSI 301 908-13: 2019 IMT cellular networks, Evolved Universal Terrestrial Radio Access User Equipment

RED art 3.3.e Network protection

EN 18031-1: 2024 Common security requirements for Internet connected radio equipment

RED art 3.3.f Personal data protection

EN 18031-2: 2024 Common security requirements for radio equipment processing data

RED art 3.3.g Protection from fraud

EN 18031-3: 2024 Common security requirements for Internet connected radio equipment processing virtual money or monetary value

Authorized signatory,

Stefan Grosjean, CEO





Ondertekend door: 27-jun-2026

A7AEF5470392469...

DoC nr : EU DoC EVD v02

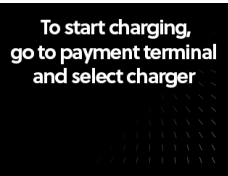

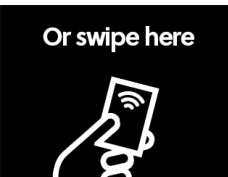
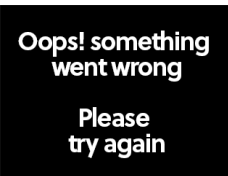
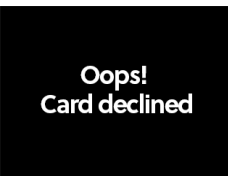
Display information

Image	Explanation
	<p>Default welcome message.</p> <p>Image is configurable using the Smappee Dashboard.</p> <p>16-Bit image should be maximum 320 x 240 pixels (or smaller).</p>
	<p>Message after plugging in the charging cable and charging station uses authenticated charging.</p> <p>There are three options to start the charging session. Either use a Smappee Pay station.</p>
	<p>Second option when authenticated charging is used.</p> <p>The charging session is started by scanning the QR code on the display.</p>
	<p>Third option when authenticated charging is used.</p> <p>The charging session is started by swiping your RFID card at the display.</p>
	<p>The charging session could not be started.</p> <p>Verify if the charging cable is connected properly and try again.</p>
	<p>Message received when charging station declined your RFID card.</p> <p>Contact the supplier of the RFID card.</p>
	<p>Something is wrong or the charging station has been disabled.</p> <p>Enable the charging station with the Smappee App or contact your installer.</p>



NOTE

You can add additional images through the Smappee Dashboard.
All images must be 16-bit and no larger than 320 × 240 pixels.

Charging station diagnostics

Although Smappee charging stations are engineered for reliable, trouble-free operation, real-world conditions may still result in faults. To assist installers and customers, an integrated diagnostic system is provided, including error codes displayed directly on the device.

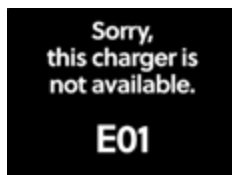

Image 44: Example error message on display

Error code	Explanation
E01	No access to NTP Server. Access to a Network Time Protocol server requires connection through port 123. Check network connectivity and firewall.
E02	No IP address received. A DHCP server needs to be available on the network of the charging station to retrieve a valid IP address. Check network connectivity and firewall.
E03	No connectivity with Smappee cloud. Check network connectivity and firewall.
E10	RCM error detected. Ongoing charging session is stopped. Disconnect the vehicle and inspect the charging cable and connector for visible damage. Try a different cable or vehicle, if possible. Contact a qualified installer or service technician if the error persists.
E20	Negative voltage on Control Pilot (CP). Disconnect the vehicle and inspect the charging cable and connector for visible damage. Try a different cable or vehicle, if possible. Contact a qualified installer or service technician if the error persists.
E21	Too high voltage on Control Pilot (CP) Disconnect the vehicle and inspect the charging cable and connector for visible damage. Try a different cable or vehicle, if possible. Contact a qualified installer or service technician if the error persists.
E22	EV goes to CP E state. This means the electric vehicle has indicated a fault condition on the Control Pilot (CP) line, and charging must be stopped immediately for safety reasons. Disconnect the vehicle and check the vehicle dashboard for error messages.

Error code	Explanation
E30	<p>Illegal voltage value on Proximity Pilot (PP)</p> <p>Disconnect the vehicle and inspect the charging cable and connector for visible damage. Try a different cable or vehicle, if possible.</p> <p>Contact a qualified installer or service technician if the error persists.</p>
E40	<p>RFID reader not found</p> <p>This message indicates that, at startup or during operation, the charging station does not detect the RFID reader hardware, or cannot communicate with it via its internal interface.</p> <p>From the charging points perspective, the RFID reader is missing, disconnected, unpowered, or malfunctioning.</p> <p>Contact a qualified installer or service technician if the error persists.</p>
E41	<p>MID meter not found</p> <p>This message indicates that the charging station cannot detect the MID meter hardware, or cannot communicate with it over the internal interface.</p> <p>From the charging points perspective, the MID meter is missing, disconnected, unpowered, or not responding.</p> <p>Contact a qualified installer or service technician if the error persists.</p>
E50	<p>Charging cable could not be locked.</p> <p>This means that the charging station was unable to mechanically secure the connector after it was inserted, which prevents charging from starting (or causes it to stop). Cable locking is a mandatory safety feature, so the station disables charging if locking fails.</p> <p>Firmly reinsert the connector until fully seated or try a different cable, if possible.</p>

Maintenance schedule

To ensure safe and reliable operation, periodic maintenance and inspections are recommended. The frequency depends on usage and environmental conditions.



WARNING

Before starting maintenance activities, consider all safety precautions as listed in Safety instructions (page 5).



NOTE

For publicly accessible charging stations, periodic inspections may be required by local regulations. Check applicable guidelines for compliance.



NOTE

At the end of its service life, the product must be disposed of and recycled as electronic equipment, in full compliance with all applicable local laws and regulations governing electronic waste.

Task	More information
Visual inspection of the charging station	Check for visible damage or wear. If necessary, consult an installer for assessment or replacement.
Cleaning	Cleaning is optional and does not affect the operation of the charging station. For aesthetic reasons, you may wipe the unit with a dry, clean cloth. Do not use water jets, solvents, or abrasive materials.

Spare parts list

Article number	EAN	Description
i1-EN3-1	5425036931701	Smappee 3phase MID meter
EV-SOCKET-ASSY	5425036935853	EV Socket assembly
AC-RCBO-4P40A	5425036935860	RCBO Type A 4P 30 mA 40 A
EV-PCB-CONTROLBOARD-1	5425036935792	AC Charge controller with 4G modem (Connector 1)
EV-PCB-CONTROLBOARD-2	5425036935808	AC Charge controller without 4G modem (Connector 2)
EV-PCB-UIBOARD-LCD	5425036935815	UI Board with LCD
EVD-ANTENNA	5425036935822	LTE / WIFI antenna 80 cm cable
EVD-FLOOR-PEDESTAL	5425036935686	EV Dual Base Pedestal
EVD-FLOOR-KIT-B	5425036935518	EV Dual Base plate kit Black
EVD-FLOOR-KIT-W	5425036935501	EV Dual Base plate kit White
EVD-FLOOR-2C5	5425036935525	EV Dual Base 2 x 3-phase 32 A Type 2 open-ended charging cable 5 m with cable holder
EVD-FLOOR-2CS8	5425036936317	EV Dual Base 2 x 3-phase 32 A Type 2 with shutter open-ended charging cable 8 m with cable holder
EVW-CBL-HOLDER-4	5425036934191	EV Wall Cable holder - 4 pieces
EVD-FLOOR-CBL-HOLDER-2	5425036935990	EV Dual Base Cable holder - 2 pieces
EVD-WALL-KIT-W	5425036935471	EV Dual Wall plate kit White
EVD-WALL-KIT-B	5425036935488	EV Dual Wall plate kit Black
EVD-WALL-2C5	5425036935495	EV Dual Wall 2 x 3-phase 32 A Type 2 open-ended charging cable 5 m with cable holder
EVD-WALL-2CS8	5425036936300	EV Dual Wall 2 x 3-phase 32 A Type 2 with shutter open-ended charging cable 8 m with cable holder

If you need another part than listed, please contact info@smappee.com.