

# Smappee EV Ultra

## Installation manual

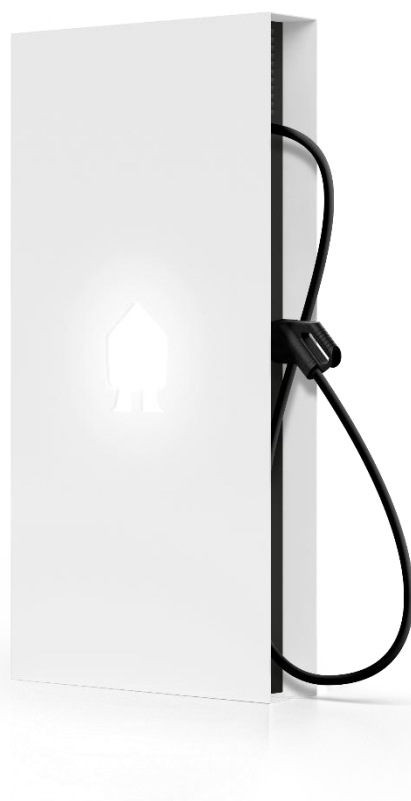

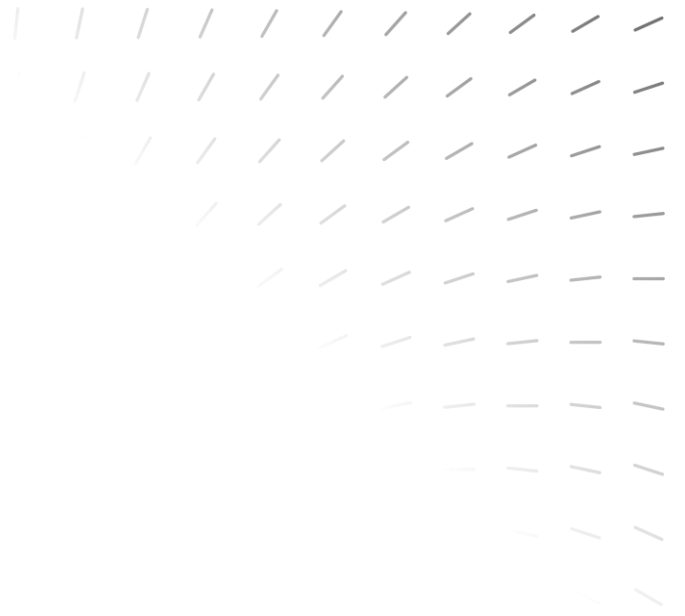

**Document Accuracy**

The specifications and other information in this document were verified to be accurate and complete at the time of its publication. Due to ongoing product improvement, this information is subject to change at any time without prior notice. For the latest information, see our online documentation: <https://www.smappee.com/downloads>

# Table of contents

1	Introduction.....	4
2	Safety instructions.....	6
3	Models.....	7
4	Components.....	8
5	Technical specifications.....	10
6	Preparing the installation.....	15
7	Installation and activation.....	17
8	Maintenance.....	40
9	Using the EV Ultra.....	43
	Declaration of conformity.....	48

# 1 Introduction

Thank you for purchasing this Smappee EV Ultra charging station for electric vehicles, the smartest DC charging station for businesses.

This installation and user manual tells you how to install and use the Smappee EV Ultra. We advise you to read the contents of this manual carefully, to ensure a safe and proper installation and enable you to use all the advanced features of this product to the full.

## 1.1 Intended use

This charging station is intended to charge electric vehicles by connection of a CCS2 charging cable without intermediate adapters. For example, to charge vehicles with an unsupported charging standard or have a longer charging cable.

Use for any other purpose than EV charging as defined in the IEC 61851-series is not and constitutes misuse of the charging station. Only qualified, trained and authorised persons are allowed to install, maintain and/or repair the charging station and make sure that the technical specifications and installation requirements are met. Incorrect installation and testing of the charging station could potentially damage either the vehicle's battery or the device. Any resulting damage is excluded from the warranty of the device. Any modification that is not in writing confirmed by Smappee will void the warranty. For more information, refer to: [smappee.com](https://www.smappee.com).

## 1.2 Support

Only qualified electricians or equivalent may install the Smappee EV Ultra. If you have any questions, please contact your service partner.

Please have the following information ready to hand to speed up the process: Article number and serial number which you can find on the identification label of the charging station.

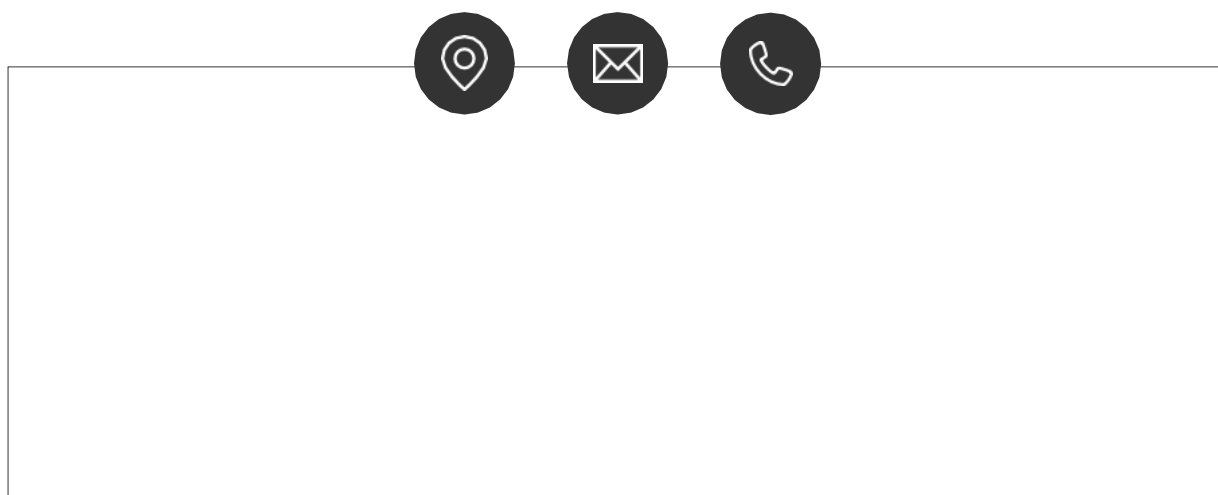

Should your local distributor be unable to help you, or you have a suggestion for us, you can contact Smappee at: **[support@smappee.com](mailto:support@smappee.com)**.

Smappee n.v.  
Evolis 104  
8530 Harelbeke  
Belgium

# 2 Safety instructions

## 2.1 Safety warning

Fully read and follow the safety instructions below before you install, service or use your Smappee EV Ultra. The installer must ensure that the charging station is installed in accordance with the relevant national and local regulations.

Carrying out activities on this charging station without the relevant knowledge and qualifications can lead to serious accidents and death. Only carry out tasks for which you are qualified and have been fully instructed.

Incorrect installation, repairs or modifications can result in danger to the user and may void the warranty and liability.

## 2.2 Safety precautions

	<b>CAUTION:</b> Risk of electric shock.
	<b>CAUTION:</b> Refer to the accompanying documentation whenever you see this symbol.

Please observe the following safety precautions to avoid potential electric shock, fire, or personal injury:

- The charging station is intended exclusively for charging electric vehicles and, when installed correctly, may be used by untrained individuals.
- Switch off electrical power supply to your charging station before installation or maintenance work.
- Do not use the charging station if damaged / defective.
- Do not immerse the charging station in water or any other liquids.
- Do not expose the charging station to heat, flame or extreme cold.
- Do not attempt to open, repair, or service any parts. Contact Smappee or your service partner for further information.
- Only use the charging station under the specified operating conditions.
- Do not allow children to operate a charging station.
- When a charging station is in use, adult supervision of any children present is required.
- While charging the charging cable must be completely unwound and connected to the electric car without overlapping loops. This to avoid the risk of overheating the charging cable.

## 2.3 Keeping order

- After charging, store the charging cable properly so it does not present a tripping hazard.
- Make sure the charging cable cannot become damaged (kinked, compressed or driven over).
- Do not place any objects on the charging station.

### 3 Models

<b>Article no.</b>	<b>EAN</b>	<b>Description</b>
EVBU-80-CCS3R	5425036933873	Smappee EV Ultra 80S
EVBU-200-CCS3R	5425036933767	Smappee EV Ultra 200S

# 4 Components

## 4.1 Components included

### 80 kW version

- 1x EV Ultra 80S
- 1x Charging cable CCS 250 A 3.25 m
- 3x Inverter
- 1x Mounting anchor

### 200 kW version

- 1x EV Ultra 200S
- 1x Charging cable CCS 250 A 3.25 m
- 5x Inverter
- 1x Mounting anchor

## 4.2 Article codes

<b>Article no.</b>	<b>EAN</b>	<b>Description</b>
EVBU-CNV40-1	5425036933774	EV Ultra Inverter 40 kW
EVBU-ANCHOR	5425036933828	EV Ultra Mounting anchor
EVBU-CBL-CSS250-3	5425036933842	EV Ultra Charging Cable CCS 250 A 3.25 m

## 4.3 Identification label

The identification label of your charging station is located near the emergency stop button, on the bottom of the front panel.

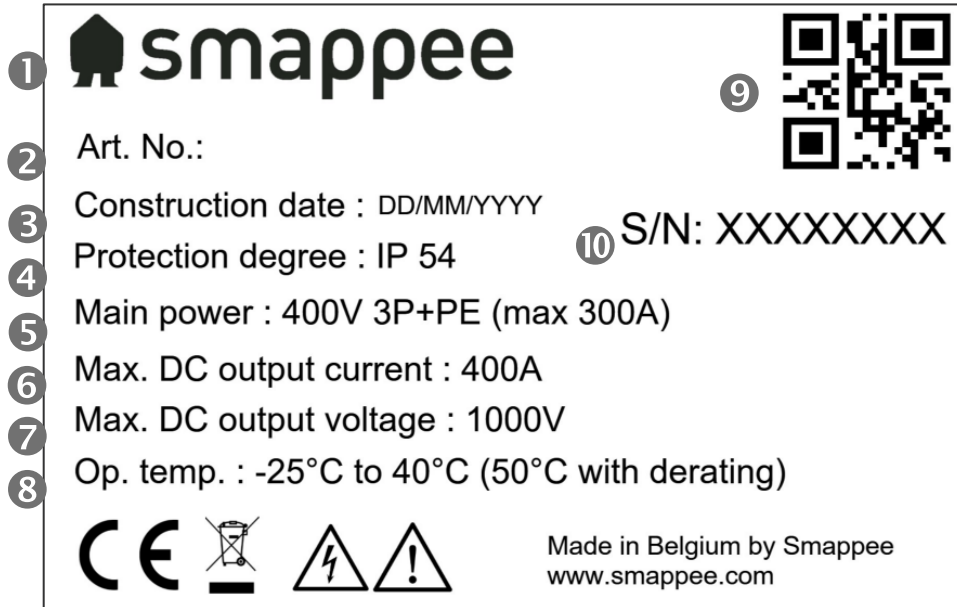

1. Manufacturer
2. Article number
3. Manufacturing date
4. Degree of protection
5. Rating
6. Maximum DC output current
7. Maximum DC output voltage
8. Operating temperature
9. QR code containing article number and serial number
10. Serial number

## 5 Technical specifications

Feature	Description	
	EV Ultra 80S	EV Ultra 200S
<b>Nominal input</b>		
Power supply	3P + PE	
Auxiliary Power supply	5G2.5 mm <sup>2</sup>	
Rated voltage (U <sub>n</sub> )	400 Vac ± 10%	
Rated frequency (f <sub>n</sub> )	50 Hz	
Nominal input current	125 A	300 A
Power factor	>0.98 at full capacity	
Efficiency	95% at full capacity	
Connection method	AC, permanently connected	
Integrated protective measures	Galvanically isolated inverters 30 mA RCD Type A for electronics	
<b>DC output</b>		
Charge mode	Mode 4 (IEC 61851)	
DC Plug	CCS2	
Connection case	Case C (fixed cable)	
Maximum current	266 A	400 A
Voltage	100 V – 1000 V	
Nominal power	80 kW at 300 V – 1000 V	200 kW at 500 V – 1000 V
<b>Interfaces &amp; Connectivity</b>		

Information status	RGB LED
Session activation	unauthenticated, Scan QR code, Swipe RFID card, Smart EV schedules
Connectivity	Ethernet 100BASE-T LTE Cat M1 (4G)
Communication protocol	OCPP 1.6 JSON, ready for update to OCPP 2.0
Metering	kWh meter compliant with IEC 62053-21
<b>Certifications and Standards</b>	
Product certification	CE
Standards	IEC 61851, ISO 15118
<b>Environment</b>	
Enclosure material	Magnelis
Enclosure standard colours	RAL9016 (star white) + RAL7021 (black grey)
Protection degree	IP54
Mechanical impact protection	IK10
Pollution degree	3
Electrical safety class	I
Stand-by use	LED brightness 0%: 90 W LED brightness 100%: 100 W
Acoustic noise	0 dB – 60 dB
Environmental conditions	Indoor and outdoor use
Operating temperature	-25 °C to 40 °C (50 °C with derating)
Storage temperature	-25 °C to 60 °C
Relative humidity	0 % - 95 %, non-condensing

Maximum installation altitude	0 – 2.000 m	
Access	Locations with restricted and non-restricted access	
<b>Physical properties</b>		
Dimensions	1860 x 920 x 290 mm	
Total Weight (excl. packaging)	230 kg	270 kg
Front panel	31 kg	31 kg
Rear panel	26 kg	26 kg
Central unit	84 kg	84 kg
Inverter (each)	20 kg	20 kg
Charging cable	9 kg	9 kg
Anchor	20 kg	20 kg
Charging cable length	3.25 m	
Stationary / moveable	Fixed installation	
External design	Enclosed assembly	
Mounting method	Floor / Ground-mounted	

	<p>The operating temperature assumes the ambient temperature of a product delivered in the default enclosure colours RAL9016 (star white) + RAL7021 (black grey). Direct exposure to sunlight may have an adverse effect on the temperature range.</p>
	<p>If the product is exposed to lower or higher ambient temperatures, continuous operation cannot be guaranteed. If temperatures exceed the maximum values, the charging station will automatically decrease the charging current to decrease the internal temperature of the charging station. This stabilises the internal temperature and makes it less likely that a transaction will be unexpectedly paused.</p>
	<p>If the product is directly exposed to sunlight, the automated temperature management may automatically start below the maximum ambient temperature. Therefore, wherever possible, avoid exposing the charging station to direct sunlight.</p>
	<p>Where products are exposed to the elements of nature, the enclosure can be subject to gradual aging of the material, which can result in product discolouration over time. Therefore, wherever possible, place the product in a sheltered place to optimise the life of the materials.</p>

## 5.1 Performance graphs

The following graph shows the DC output power for both the 80kW and 200kW EV Ultra, related to the AC input line voltage.

For both EV chargers, no DC output is produced if the input line voltage is below 320V or above 475V. Small variances in the normal input line voltage (for example between 400V and 410V) will not cause any change in the DC output power.

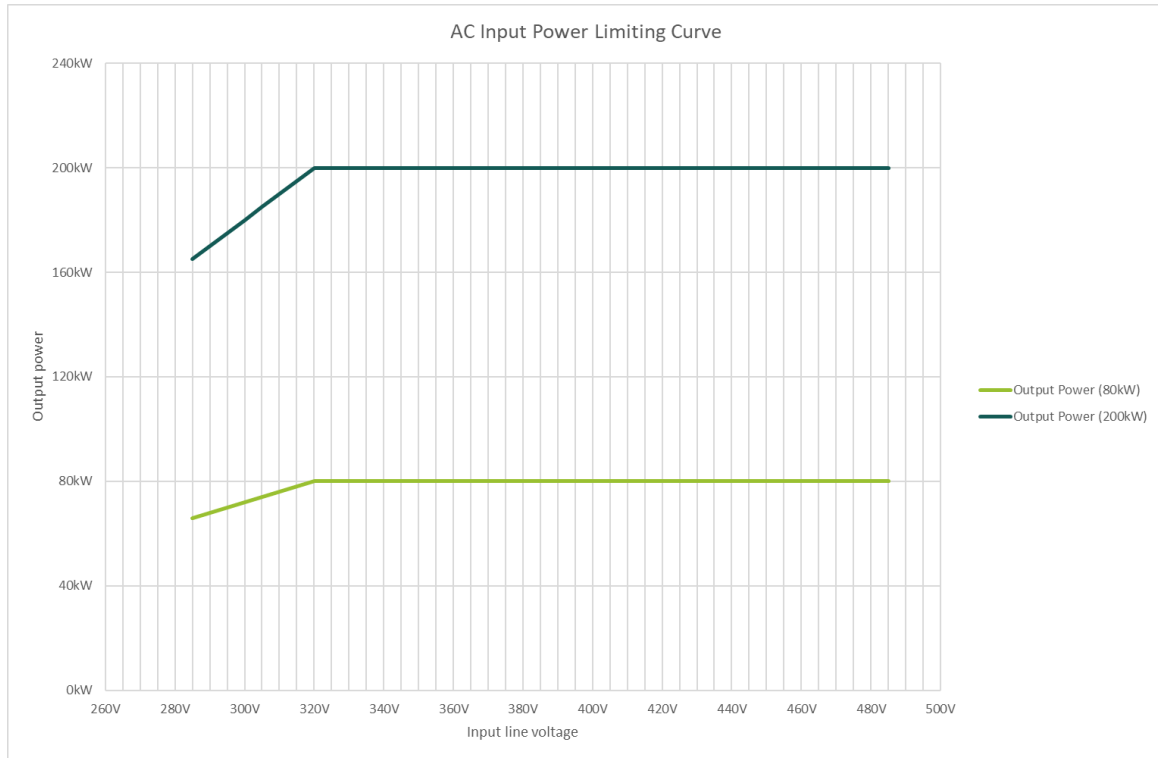

The next graph shows the maximum output current as a function of output voltage. The output voltage is determined by the vehicle's battery, where most vehicles require voltages of approximately 400V or 800V. The Smappee EV Ultra can provide voltages between 100V and 1000V.

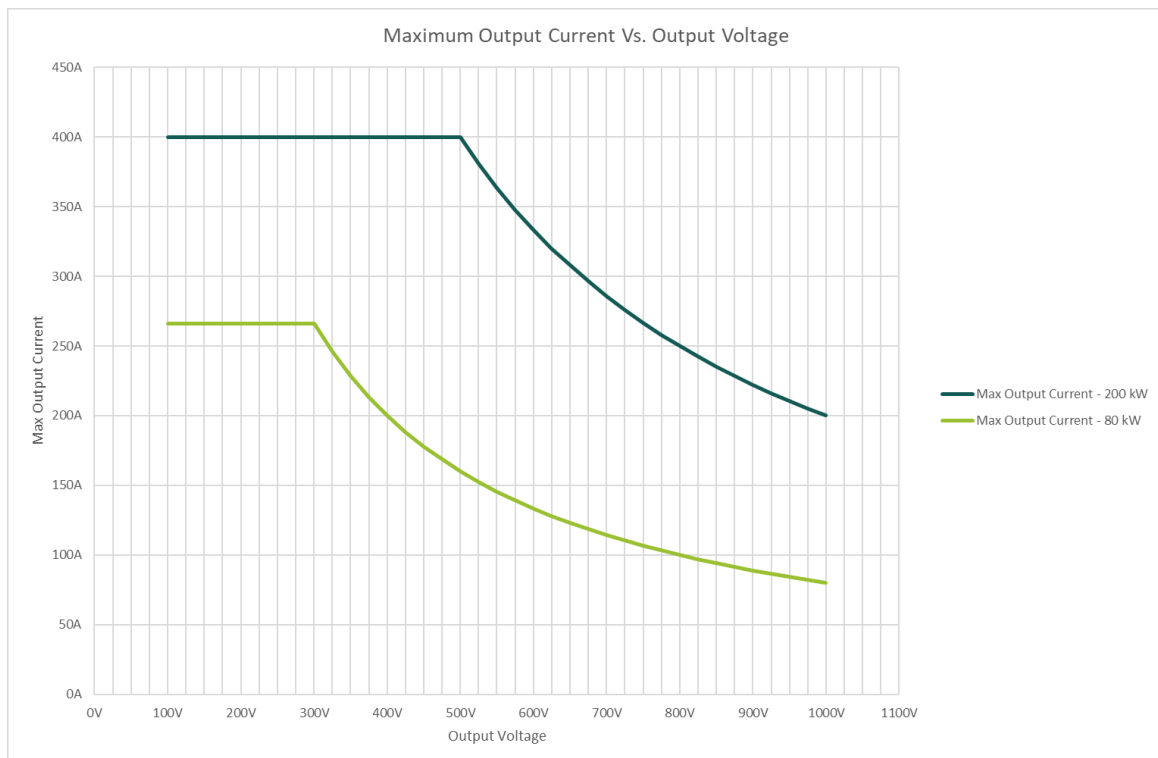

# 6 Preparing the installation

First step is to prepare the physical installation of the EV Ultra as described in this chapter.

## 6.1 Installation prerequisites

- Calculate the existing electrical load to find the maximum operating current for the charging station installation. Note that with the Smappee Overload functionality more charging stations or the total maximum operating current can be higher than the physical installation allows.
- Obtain all necessary permits from the relevant local authority.
- Refer to local wiring regulations to select the conductor sizes and use only copper or aluminium conductors.
- Make sure that the installation area of the charging station is adequate for usability and ventilation purposes.
- Use the correct tools and provide sufficient material resources and protection measures.
- Make sure that there is an Ethernet based internet connection available for each EV Ultra (1 per unit). It is possible to operate the station using only its 4G connection, but this is not recommended.

## 6.2 Power supply

- The appropriate wire gauge of the supply cable depends on the power rating and distance between the meter cabinet and the charging station. The voltage drop must not exceed 5%. It is advisable to have a maximum voltage drop of 3 %.
- The maximum cable lug that can be fitted has a width of 32 mm.
- The power supply trajectory from the circuit breaker panel up to the EV Ultra charging station must be protected against short-circuiting and over-current with B or C circuit breakers (or otherwise in compliance with local standards and regulations)
- A charging station connector must always be installed on a dedicated power circuit.
- When the power supply and the charging station are part of a TN-S system, the station must be grounded via the main distributor.
- Route the power supply cables to the position where the charging station will be installed together with an Ethernet cable for the internet connection.
- Make sure the power supply cables are positioned through the central position of the EV Ultra anchor.
- Make sure that there is at least 30 cm available out of the ground.
- Local regulations may be applicable and can vary depending upon the region or country.



The power line enters the charging station via the floor plate.

The Ethernet cable, used for the internet connection, enters the charging station via the EV Ultra anchor.

The maximum power rating for each connector is specified in the table below.

<b>Power per connector</b>	<b>Connection</b>	<b>Input current</b>	<b>Output current</b>
80 kW	3-phase	3 x 125 A	DC 266 A
200 kW	3-phase	3 x 300 A	DC 400 A

### 6.3 Tools (not included)





- Screwdrivers
- Hex key set
- Multimeter and earth ground meter
- Wire stripper and cutter.
- Needle-nose pliers.
- Cable lugs M10 with a maximum width of 35 mm
- 17 mm socket wrench with ratchet handle

### 6.4 Supplies (not included)

- Ethernet cable and RJ45 connector for wired communication.
- Power supply cables

# 7 Installation and activation

This procedure describes the required steps for the physical installation of the EV Ultra.

	<p><b>CAUTION:</b> The installation must be carried out by a qualified professional who has read this manual and works in compliance with IEC 60364 standards. Neglecting this may lead to severe injuries or hazardous situations while working with electricity.</p>
	<p><b>CAUTION:</b> The electric system must be entirely disconnected from every power source prior to performing installation or maintenance work. Make sure it is not possible to connect the electric current during installation. Put up caution tape and warning signs to mark the work areas. Make sure no unauthorised people can enter the work areas.</p>
	<p><b>CAUTION:</b> Hazardous electrical voltages are present in the EV Ultra (up to 1000V)</p>
	<p><b>CAUTION:</b> The charging station contains electric components that may still contain electrical charge after being disconnected. Wait at least 10 seconds after disconnection before commencing work.</p>
	<p><b>CAUTION:</b> Adaptors or conversion adaptors and cord extension sets are not allowed to be used.</p>
	<p>The EV Ultra contains components and circuits boards sensitive to electrostatic discharge. Sufficient ESD measures should be taken to protect the components during installation and maintenance.</p>
	<p>Components of the EV Ultra can be very heavy, for example the inverters.</p>
	<p>Take care that components don't squeeze a human body or body part while assembling or disassembling.</p>

## 7.1 Transport, storage and unboxing the EV Ultra

### Transport and storage

- Disconnect electrical power supply before removing the charging station for storage or relocation.
- Only transport and store the charging station in its original packaging. No liability for damage incurred will be accepted if the charging station is transported in non-standard packaging.
- Store the charging station in a dry environment within the temperature range specified in the technical specifications.

## Unboxing

The charging unit, charging cable, inverters and anchor are delivered in separate boxes. Make sure to use the proper equipment or enough people to move the different components.

Especially the charging unit and inverters need more than one person to lift.

Unboxing the different components doesn't need special attention. Just keep in mind to store the cardboard, as this can be used to safely store the front and back panel while installing the EV Ultra.

## 7.2 Assemble the EV Ultra anchor

The Smappee EV Ultra is designed to be installed at ground level using the supplied anchor.

It is mandatory to use this anchor.



Only top and bottom of the anchor are determined.

There is no specified front or back on the EV Ultra anchor.

In order to guarantee compact transportation, the anchor is supplied in a kit and needs assembling.

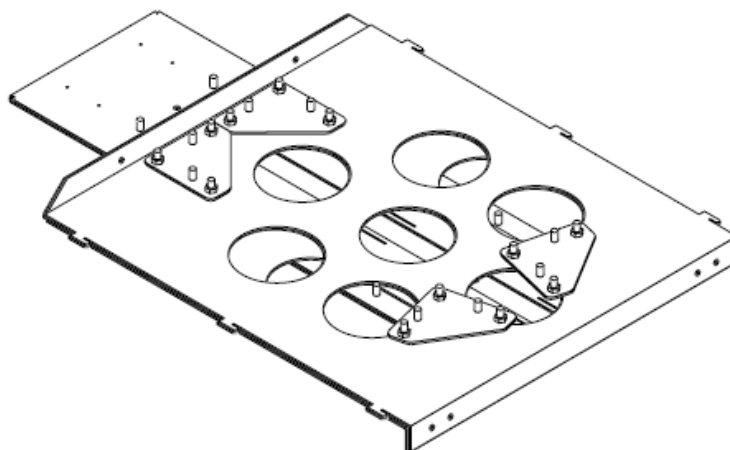

The dimensions of the assembled anchor are as followed.

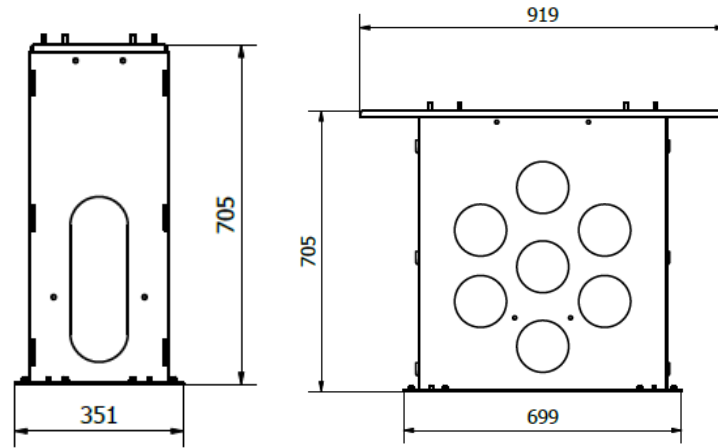

Follow these instructions to assemble the different parts:

- Remove the nuts from the anchor kit and separate each part

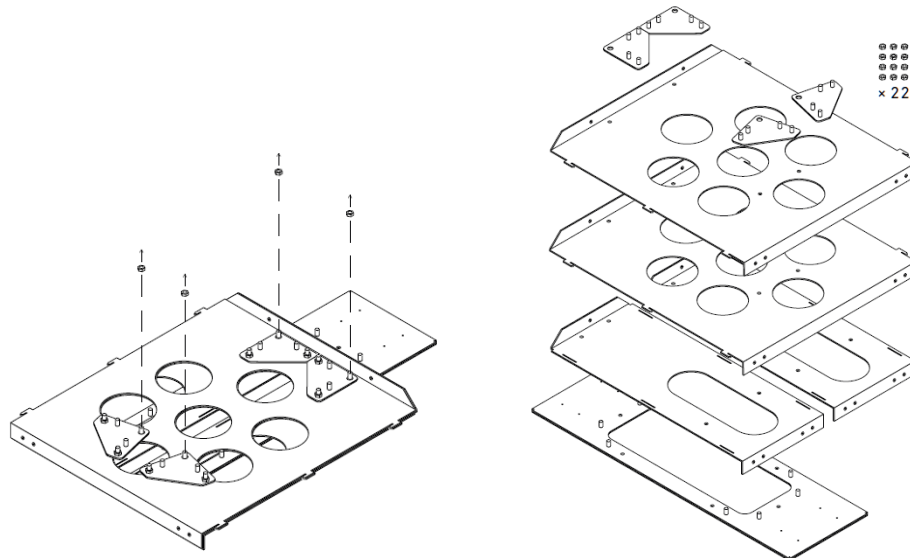

- Join the 4 side panels using the grooves. Hand tightening the 4 mounting corners at the bottom of the assembling using the supplied nuts.

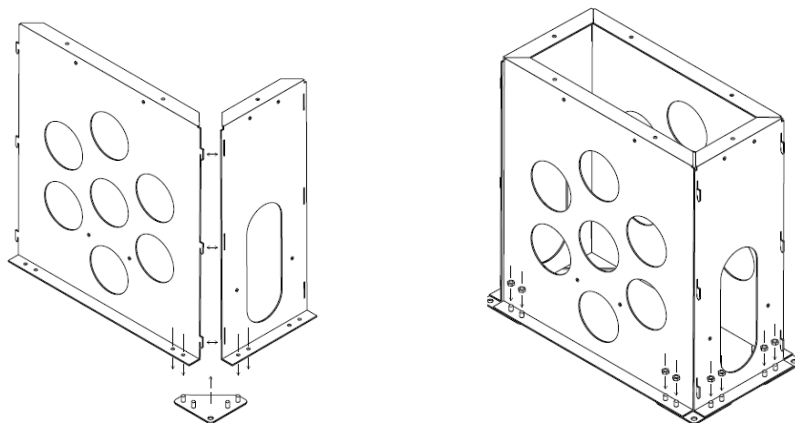



Do NOT torque the nuts yet. This is done during the last step of the assembly.

- Place and secure the cover plate on the top using the supplied nuts and a socket wrench. Tighten the 4 mounting corners at the bottom of the assembling using a socket wrench.

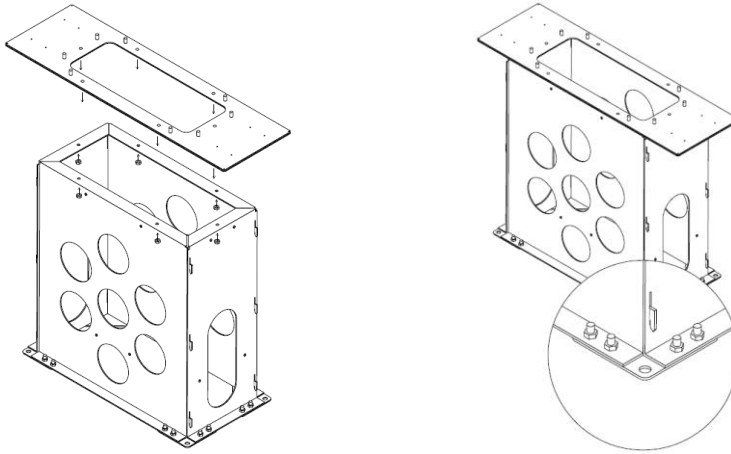

The cover plate is a dummy plate to determine the correct dimensions, and thus perfect positioning of the EV Ultra anchor. This dummy cover plate is removed from the anchor before placing the EV Ultra on the anchor.

- The EV Ultra Anchor is now ready to host the charging station

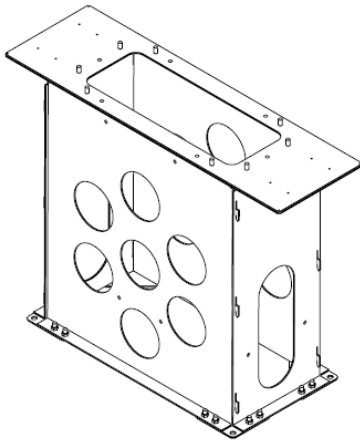

### 7.3 Mount the EV Ultra anchor

A stable and level ground needs to be prepared in advance. We advise a levelled concrete foundation at ground level minus the height of the anchor. It is also possible to have the foundation a little lower. This allows the EV Ultra to be integrated in the surrounding soil.

When mounting the EV Ultra anchor, there is no left or right side of the anchor. Only the top and bottom needs to be considered, where the dummy plate of the EV Ultra is the top. In other words: the anchor can be turned 180° to the left of right, but cannot not be flipped.



The EV Ultra can be placed maximum 3 cm below the top of the surrounding soil for aesthetic purposes. It cannot be placed lower as there will be risk of water ingress.

To correctly install the EV Ultra anchor:

- a. Create a foundation made of a dry mixture of sand and cement. The minimum dimensions of this foundation are 450 mm by 750 mm. This is a bit larger than the dimensions of the anchor, to make sure a stable foundation is created.
- b. Reinforce the corners of the foundation using a concrete block.
- c. Make sure the concrete blocks are level in both directions. If not, adjust until level.
- d. Place the EV Ultra anchor on the concrete blocks. If needed, the position of the anchor is fixed by pushing a hub through the holes in the corner.

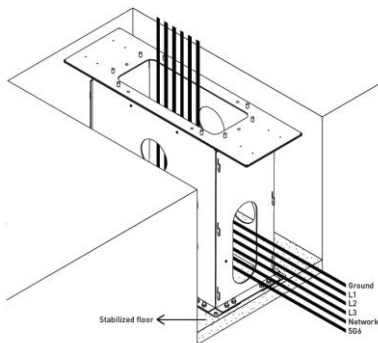

- e. Route all necessary cables through the anchor. This includes power supply, ground and ethernet cables.

To make sure all necessary cables are present, check the serial number of the EV Ultra:

- a. Serial number  $\geq$  630000200
  - i. Power supply for the inverters: phases 1, 2, 3 and ground.
  - ii. Auxiliary power supply: 5G2.5 mm<sup>2</sup>.
  - iii. Ethernet cable for internet connectivity.
- b. Serial number  $<$  630000200, on a TN-C net

- i. Power supply for the inverters: phases 1, 2, 3 and ground.
    - ii. Ethernet cable for internet connectivity.
  - c. Serial number < 6300000200, on a TN-S net
    - i. Power supply for the inverters: phases 1, 2, 3 and ground.
    - ii. Auxiliary power supply: 5G2.5 mm<sup>2</sup>.
    - iii. Ethernet cable for internet connectivity.
- f. Fill the anchor with concrete until half of the anchor is filled with concrete. It is normal that some excess concrete pours out of the holes. Use this excess to further fix the anchor to the foundation.

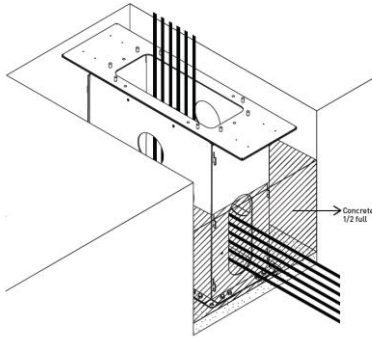

- g. Wait for the concrete to cure before going to the next steps.

The EV Ultra anchor is now secured in place and ready for the EV Ultra to be mounted.

## 7.4 Place the EV Ultra on the anchor

- a. While the EV Ultra is in the cardboard box, first remove the backplate of the EV Ultra. The back plate is the one without the Smappee avatar. This removes some weight from the charger and provides extra grip.  
Remove the backplate of the EV Ultra by unscrewing the 12 screws (using a 5 mm hex screwdriver) and put it in a safe location where it cannot be scratched or damaged otherwise; for instance in the packaging of the EV Ultra.

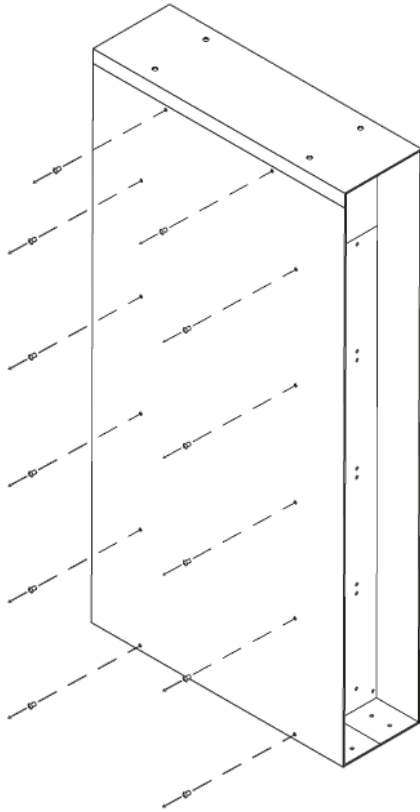

- b. Put the EV Ultra in an upright position. By tilting the EV Ultra back and forwards, the cardboard is removed underneath the charging unit.
- c. Remove the front plate of the EV Ultra by unscrewing the upper 4 screws (using a 5 mm hex screwdriver). After unscrewing the 4 screws, the front plate can be removed by lifting and moving it forward. Put it at a safe location where it cannot be scratched or damaged otherwise; for instance in the packaging of the EV Ultra.

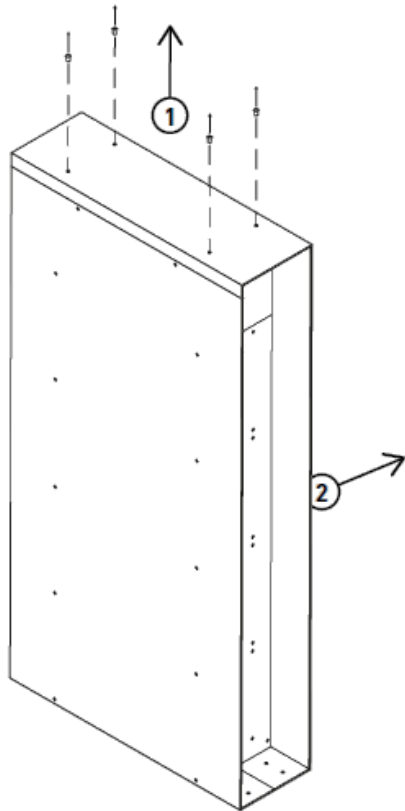

- d. When assembling the EV Ultra anchor, a dummy top plate is used to determine the correct dimensions. This dummy plate has the correct dimensions, but not the correct solidity for the EV Ultra.  
Therefore, the final plate is already mounted to the EV Ultra unit for easy installation. In order to place the EV Ultra on the installed anchor, first remove the dummy top plate of the installed anchor.  
  
Leave the top plate mounted to the charging station as is.
- e. Place the EV Ultra (with plate) over the anchor. Make sure all holes align with sides of the anchor and the power supply and ethernet cables go through the central opening of the EV Ultra.



- f. Use the supplied nuts to secure the EV Ultra to the anchor. Tighten the nuts using a socket wrench.



## 7.5 Power supply connection for serial numbers

**>= 6300000200**



Before continuing with the power supply connection, first check the serial number.  
Only continue reading this section if the serial number is 6300000200 or higher.

The EV Ultra has two distinct power supplies:

1. Power supply for the inverters, being 3 phases and the ground (PE).
2. An auxiliary power supply for the internal electronics of the EV Ultra, being a 5G2.5 mm<sup>2</sup> cable.

### Power supply for the inverters

Use cable lugs M10 with a maximum width of 35 mm and connect phase 1, 2 and 3 to the load break switch. The screws should be tightened with a torque of **26 Nm**.

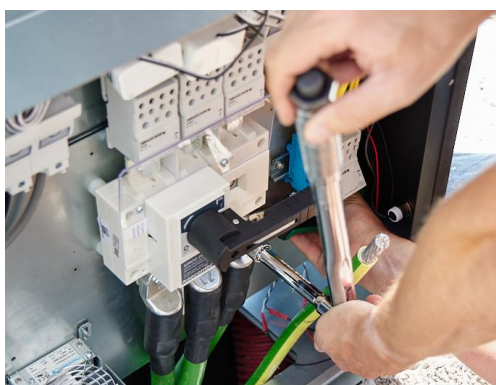

Protect the power supply cables using the plastic cover of the load break switch.



Connect the ground (PE) to the distribution block on the right of the EV Ultra, using an 8 mm hex wrench. Tighten it to **25 Nm**.



### Auxiliary power supply

For the internal electronics of the EV Ultra, an extra 5G2.5 mm<sup>2</sup> cable is needed. This 5G2.5 mm<sup>2</sup> cable is connected to the internal 20 A fuses and connector available at the bottom right corner.

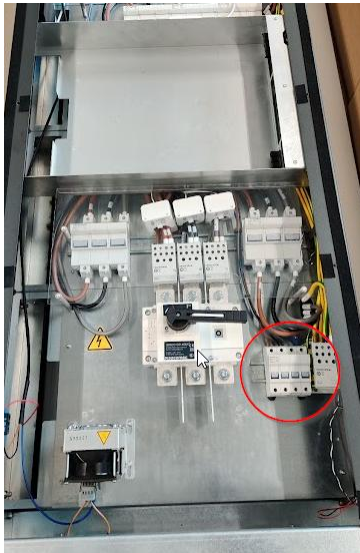

Phases 1, 2, 3 and neutral are directly connected to the fuses, while the ground is connected to the connector just right of the fuses.

Make sure to respect the phase assignment as depicted below.

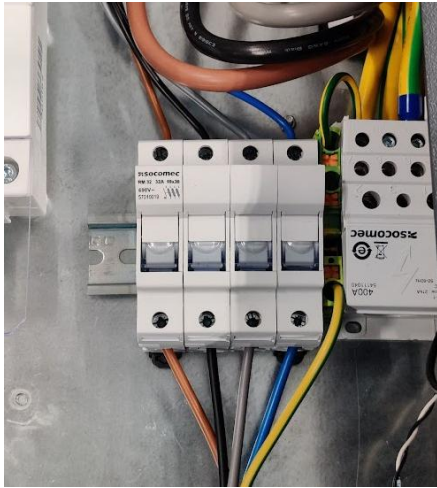

## 7.6 Power supply connection for serial numbers

< **6300000200**



Before continuing with the power supply connection, first check the serial number.  
Only continue reading this section if the serial number is lower than 6300000200.

### TN-C grid

In a TN-C grid, a combined PEN conductor fulfils the functions of both a PE and an N conductor. This means only 4 conductors are needed for this type of installations: 3 phases and 1 (PEN) ground cable.

The internal wiring of the EV Ultra assumes a TN-C grid by default. Reason why a connection is made between the neutral and ground connection.

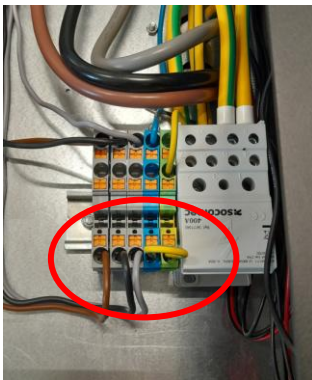

Use cable lugs M10 with a maximum width of 35 mm and connect phase 1, 2 and 3 to the load break switch. The screws should be tightened with a torque of **26 Nm**.

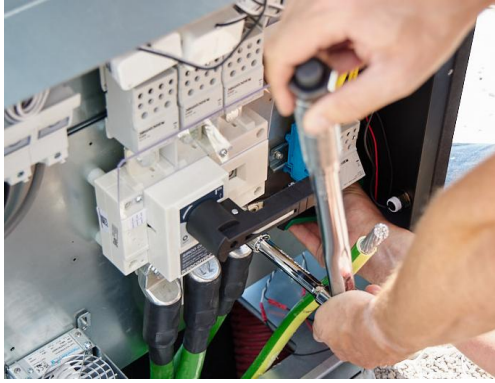

Protect the power supply cables using the plastic cover of the load break switch.



Connect the ground to the distribution block on the right of the EV Ultra, using an 8 mm hex wrench. Tighten it to **25 Nm**.



### **TN-S grid**

In a TN-S grid, the PE and N are separate conductors that are connected together only near the power source. This means that besides the conductors for the power supply of the EV Ultra, an extra 5G2.5 mm<sup>2</sup> cable is needed.

Remove the pre-wired cable from both the distribution block and the connecting block

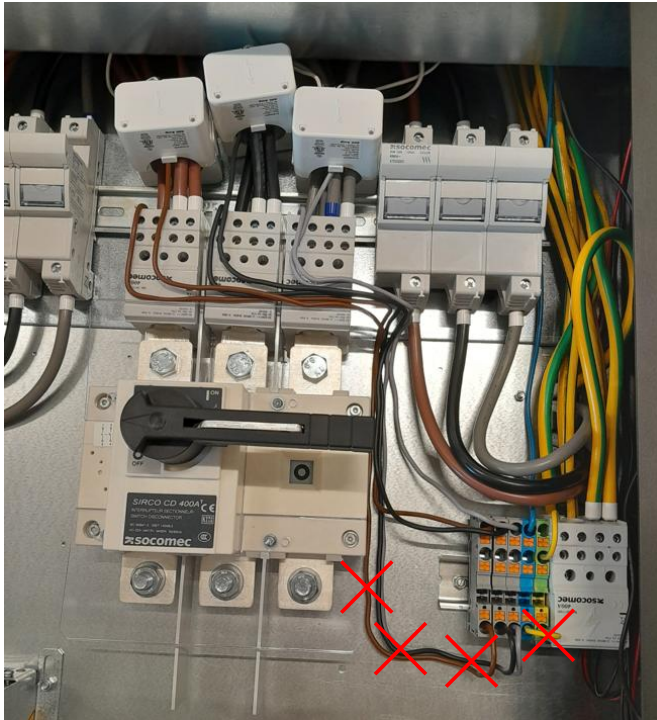

The picture below shows the situation after removing the pre-wired cables:

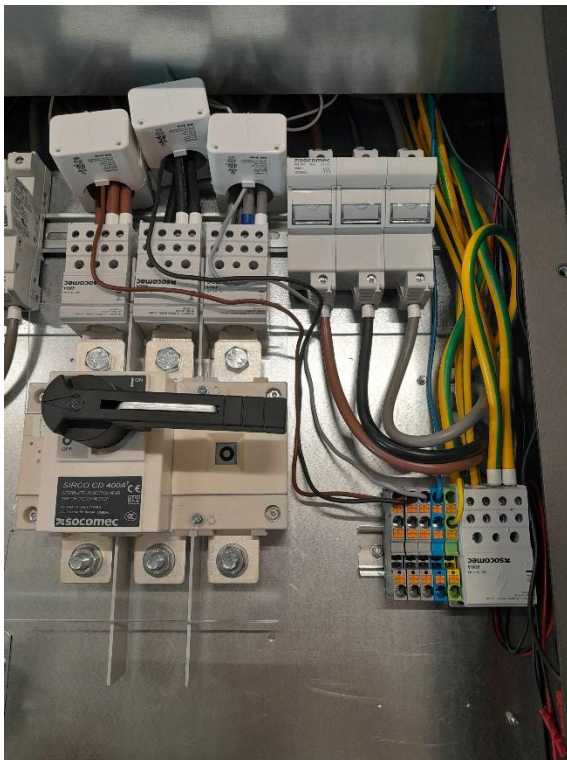

Mount the 5G2.5 mm<sup>2</sup> cable to the connecting block, respecting the colour assignment. The 5G2.5 mm<sup>2</sup> cable is secured with a 20 A circuit breaker in the distribution panel.

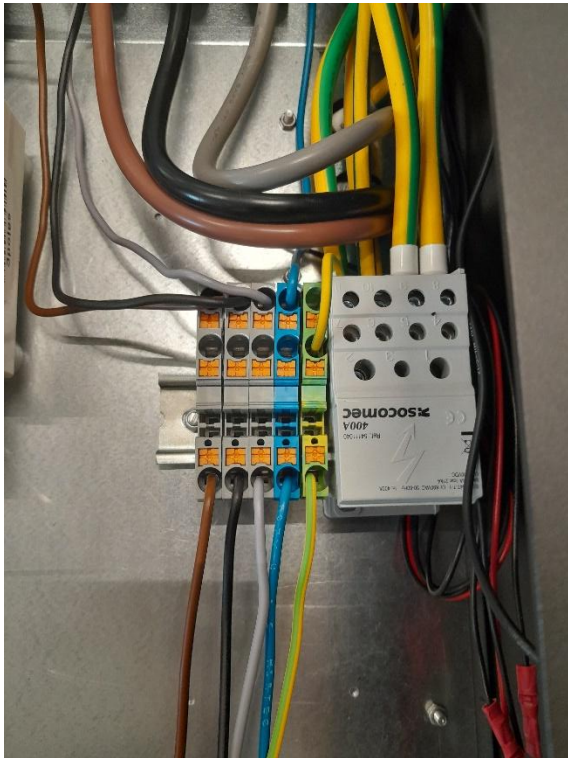

After removing the pre-wired cable and installation of the 5G 2.5 mm<sup>2</sup> cable, the installation of the power supply cables is the same as for a TN-C grid.

Use cable lugs M10 with a maximum width of 35 mm and connect phase 1, 2 and 3 to the load break switch.

Connect the ground to the distribution block, just like in a TN-C grid.

## 7.7 Mount the inverters

In order to access the middle inverter slot on the front, first remove the metal beam holding the RFID reader. To do this, use a 2.5 mm hex wrench.



The inverters in the back have the DC output at the bottom of each slot, while the inverters in the front have the DC output at the top.

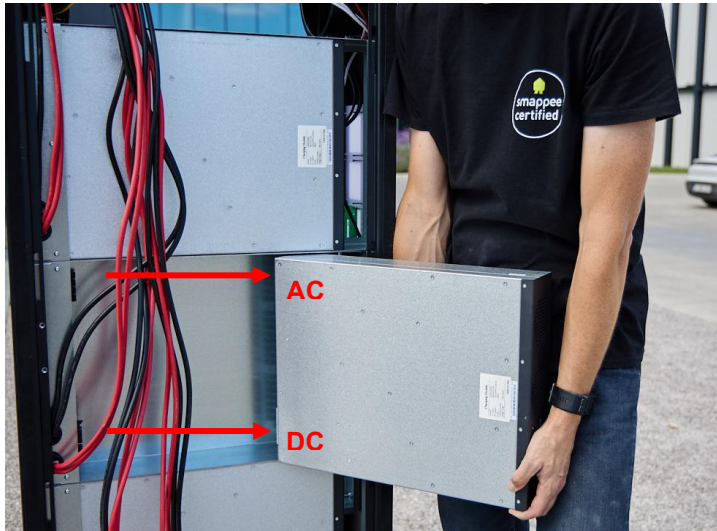

The inverter is into position when the right side of the inverter touches the right side of the slot.

After mounting the inverters, remount the metal beam with the RFID reader.



## 7.8 Mount the inverters for Ultra 80S

The EV Ultra 80S is supplied with three inverters. As the EV Ultra 80S has the same housing as the EV Ultra 200S, it is important to only use the slots reserved for the EV Ultra 80S.

The reserved slots for the EV Ultra 80S are two in the front and one in the back of the housing. Refer to the picture below to identify the correct slots.

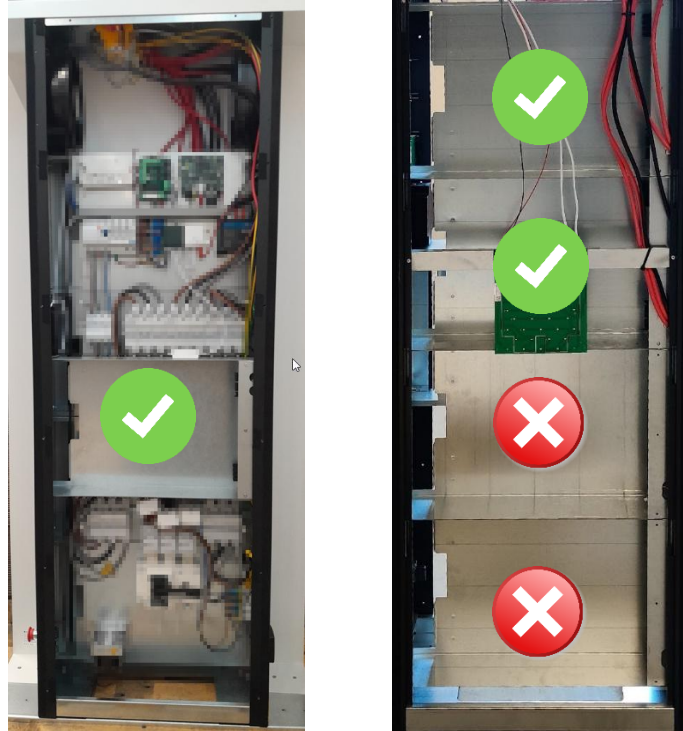

## 7.9 Mount the inverters for Ultra 200S

The EV Ultra 200S is supplied with five inverters. Each inverter slides into a foreseen slot. There are four slots in the back and one in the front.

There is no specific order to be respected when mounting the inverters into the slots.

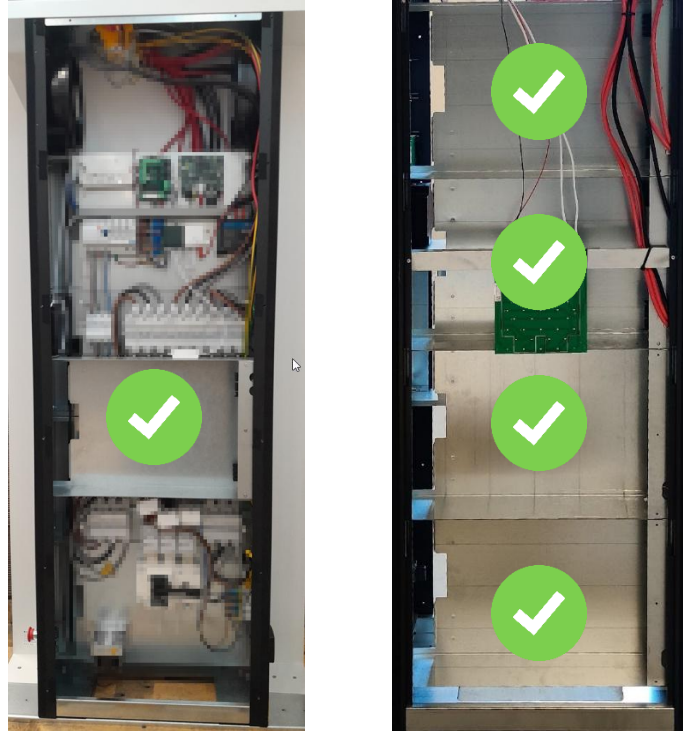

## 7.10 EV charging cable mounting

In order to prevent damaging the CCS2 connector, it is advised to plug the socket into the cable holder before starting to mount the charging cable.



Route the charging cable through the cable gland and connect ground (green/yellow), plus (red) and minus (black) to the corresponding distribution blocks using an 8 mm hex wrench. Tighten these connections to **25 Nm**.



The remaining six control cables have a label from 1 to 6. Mount each cable to the corresponding connector within the EV Ultra. Use a small screwdriver to connect the cable.

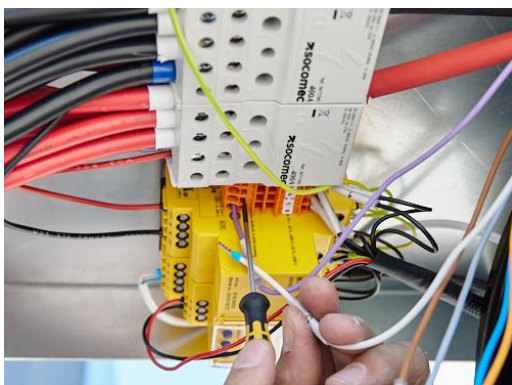

## 7.11 Determine CCS2 Socket tightness

The tightness of the CCS2 socket in the cable holder can be determined by adjusting two set screws within the housing of the EV Ultra.

- First loosen the set screw on the side of the cable holder, using a hex screw driver. This makes sure the set screw on the top can be adjusted.



- Loosen or tighten the set screw on top to determine the tightness of the CCS2 socket.



- When the desired tightness is achieved, tighten the set screw on the side of the cable holder. This makes sure the position of the top screw doesn't change when manipulating the charging cable.

## 7.12 Internet connectivity

An Ethernet cable should be used to provide network connectivity for the EV Ultra. This Ethernet cable is mounted in the open RJ-45 WAN port of the Teltonika router.

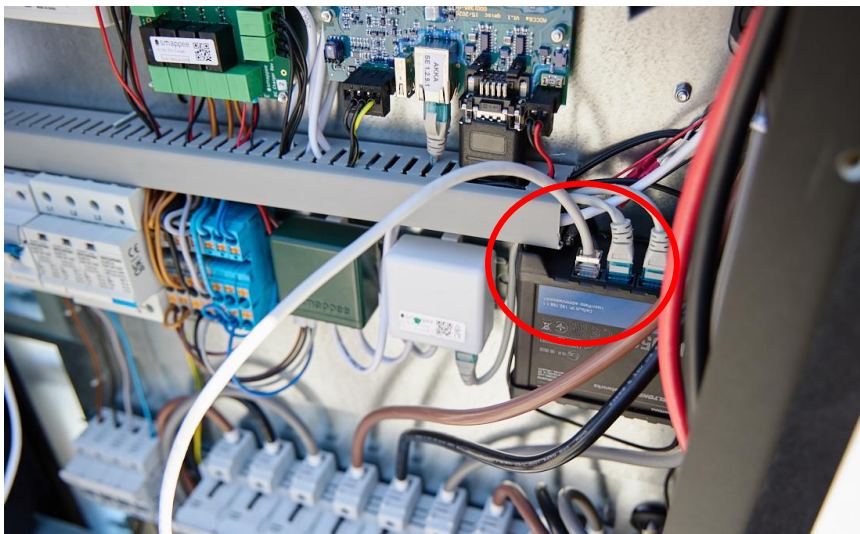

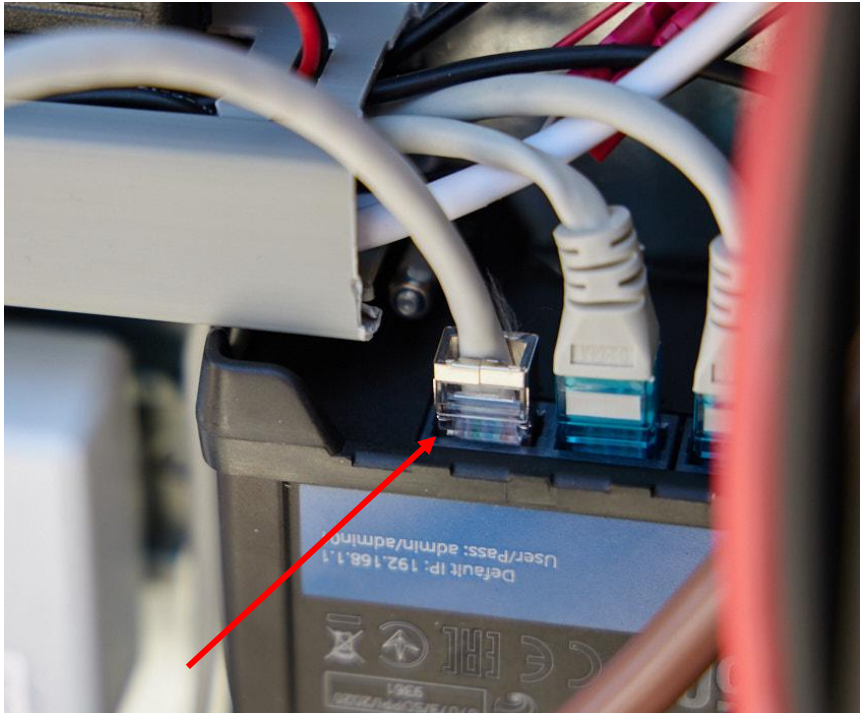

The Teltonika router creates a small, private network within the EV Ultra to provide network connectivity for all components. This private network is created within the subnet 192.168.37.0.

Each Teltonika router is configured with a 4G connection as backup in case of failure of the wired Internet connection.

## 7.13 Switch on the EV Ultra

Before switching on the EV Ultra, make sure no tools are near any power supply connections and people stand free of the EV Ultra.

After switching on the EV Ultra, wait for approximately 30 seconds to verify the following LED indicators:

- Connect gateway – Blue blinking (1x per second)
- Power Box – Pulsing 1x per 3 seconds
- CT Hub – Pulsing 1x per 3 seconds
- Charging controller – Green flashing light (1x per 3 seconds)
- Akka Board – Traffic light styled leds
- Teltonika 4G Router – Signal strength indicator
- Inverters – Green LED on the front panel is on and the red LED is off

## 7.14 Activation

This procedure is done with the Smappee mobile app. You can download this from the Apple App Store for iOS or the Google Play store for Android phones.



The Smappee App will guide you through the various steps to fill in all the required information.

- Log in to the Smappee App with the corresponding Smappee username or create a new user account.
- Install a Smappee EV Ultra.
- Follow the steps shown in the mobile app.

	Multiple charging stations can be installed at a single location. To add a new charging station in the mobile app, go to Settings > Your Smappee charging stations
	The settings of your charging station can be adjusted in the Smappee Mobile app or Dashboard.
	For overload protection or optimised self-sufficiency additional Smappee Infinity components must be installed to measure the Grid and Solar, Battery or other submetering if applicable.

## 7.15 Closure

- a. Fill the opening between the anchor and charging station with an airtight material such as polyurethane foam. This is to prevent the overpressure from the cooling fans escaping into the ground, and to stop small animals from entering the charging station via the ground.
- b. First place the front plate into position. Make sure the grooves align and the front plate slides into place.  
Do not fix the front plate with screws at this moment.



- c. Place the back plate into position and fix with the supplied screws and 5mm hex wrench.



- d. Use four screws to fix the top of the front plate, using a 5mm hex wrench.  
Front and back plate should align.
- e. To end, use 8 screws to fix the front and back plate to the floorplate of the anchor.

# 8 Maintenance

For safe and regular operation of the EV Ultra, regular maintenance or control is required. Refer to the table below for the intended maintenance work and interval.

All points in the table are considered mandatory and must be carried out by a certified technician.

Before starting maintenance activities, consider all safety precautions as listed in chapter 2, Safety instructions (page 6) and chapter 7, Installation and activation (page 17).

## 8.1 Maintenance

- Observe the maintenance schedule in the table below.
- Clean the outside only with a dry, clean cloth.
- Do not use abrasive agents or solvents.
- May not be carried out during rain or if air humidity exceeds 95%.

<b>Maintenance task</b>	<b>Maintenance details</b>	<b>Interval</b>
Charging cable	Replace the charging cable	After 10000 charging cycles
Residual Current Devices (RCDs)	Perform a function test of the residual current devices	Every 6 months
Main switch	Verify the correct operation of the main switch	Yearly
Verification of protective measures	With the charging station switched off, check the resistance between the ground of the power supply and all externally accessible parts. This can be housing, screws and other parts.	Yearly
Check for cleanliness and condensation	Open the EV Ultra and check for traces of condensation and if the interior is clean.	Yearly
Ventilation filters	Replace the filters	Yearly
Visual check	Annual visual check light over voltage protection	Yearly

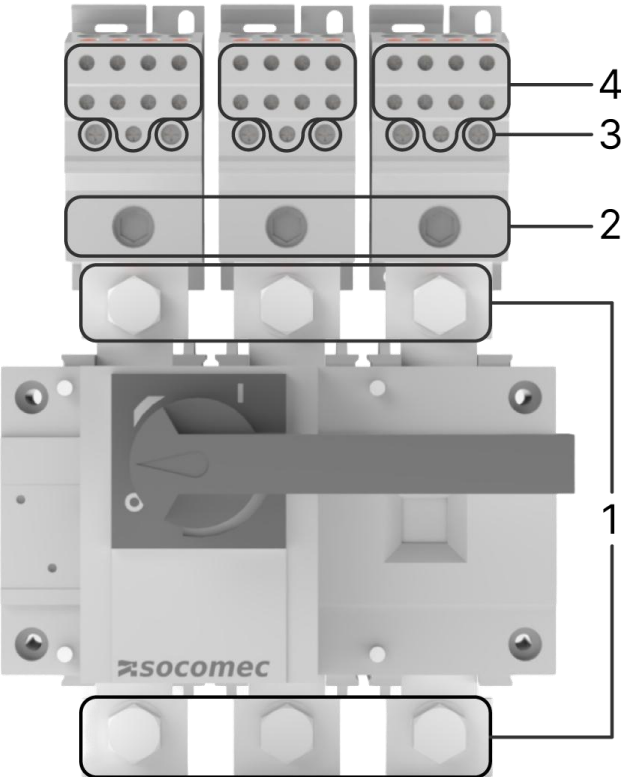
Maintenance task	Maintenance details	Interval
<p>Check tension on nuts and bolts of main power supply</p>	<p>Verify all nuts and bolts on the top and bottom of the main switch.</p> <p>The schematics below show the areas, required tools, and specified torque values.</p>  <ul style="list-style-type: none"> <li>• Area 1: SW17 key, torque 26 Nm</li> <li>• Area 2: Allen key 10 mm, torque 26 Nm</li> <li>• Area 3: Allen key 4 mm, torque 3,5 Nm</li> <li>• Area 4: Allen key 3 mm, torque 2 Nm</li> </ul>	<p>Yearly</p>

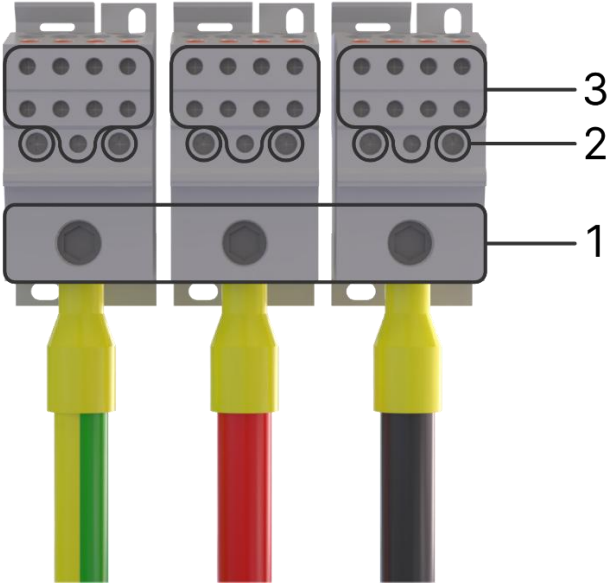
Maintenance task	Maintenance details	Interval
<p>Check tension on bolts of the charging cable</p>	<p>Verify all bolts on the connection of the charging cable in the upper corner.</p> <p>The schematics below show the area, required tools, and specified torque values.</p>  <ul style="list-style-type: none"> <li>• Area 1: Allen key 10 mm, torque 26 Nm</li> <li>• Area 2: Allen key 4 mm, torque 3,5 Nm</li> <li>• Area 3: Allen key 3 mm, torque 2 Nm</li> </ul>	<p>Yearly</p>

# 9 Using the EV Ultra

There are three ways of charging using a Smappee EV Ultra:

1. Unauthenticated charging: Simply insert the connector in the EV and start charging.
2. Swipe and charge: Insert the connector, swipe your RFID card and start charging.
3. Scan and charge: Insert the connector, scan the QR code in the Smappee App and start charging.

Below you can find the different charging sequences.

	Each EV Ultra that is installed and activated is unauthenticated charging. Changing the Session Activation Method is done using the Smappee Dashboard.
	Changing the authentication methods can be done remotely.
	Scan and charge and Swipe and charge (with Smappee CSMS) can only be used when a Smappee Payment Agreement has been signed. See <a href="#">this article</a> for more info.

## 9.1 Unauthenticated charging

The charging station is freely accessible without the need to authorize. Anyone can plug their car into the charger and start charging for free.

### Start charging



### Stop charging



## 9.2 Swipe and charge

Charging sessions can be started using an RFID card. You can either use a Smappee Smart Charge Card for free charging or (if activated) a third party eMSP card to pay for charging sessions.

The RFID readers are situated at the side of the EV Ultra, close to the connector.

- **Whitelist:** charging is free with a Smappee Smart Charge Card or any other authorized RFID card. Once the charging cable is plugged-in, the user simply swipes their RFID card and the free charging session begins. All authorized cards must first be added to the whitelist using the 'Whitelisting' card on [dashboard.smappee.net](https://dashboard.smappee.net). See [this](#) article for more information. Cards can be ordered via the Smappee dashboard.
- **Public charging:** Other EV drivers can use this charging station and pay with an RFID card / token from a third-party eMSP. This can be done through Smappee's own CPO or through a third-party CPO. Public charging is activated using the Smappee dashboard. See the [Smappee Academy](#) for more information.
- **Split Billing:** This is aimed at employees who charge their company car at home and need to be reimbursed for the electricity consumption. Split billing agreements must be made for each employee. Starting a charging session is similar to whitelisting but at the end of each month, Smappee Services will send a bill for all employees' charging sessions to the company. All individual employees will be reimbursed according to the amount of kWh charged. See [this](#) article for more information. Split billing is activated using the Smappee dashboard. See [this](#) article or the [Smappee Academy](#) for more information.

### Start charging



### Stop charging



## 9.3 Scan and charge

The user pays by credit card (Visa or Mastercard) using the Smappee App. They scan the QR code shown on the charging station and the app will guide them through the process of starting the charging session. It is also possible to set discount rates for specific users. Scan and charge is activated using the Smappee dashboard. See the [Smappee Academy](#) for more information.

### Start charging

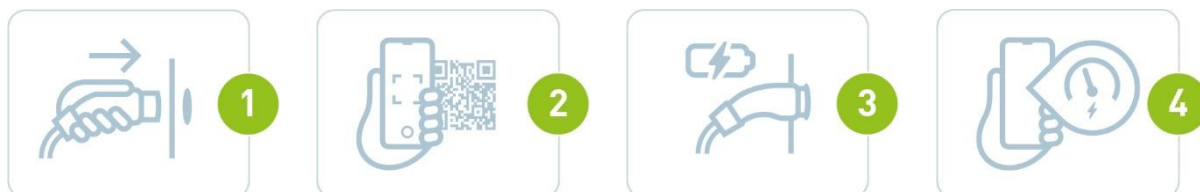

### Stop charging



More information on how to use the Smappee EV Wall Business can be found on: [support.smappee.com/hc](https://support.smappee.com/hc) > Smappee EV Line

## 9.4 LED status EV Ultra

LED colour	LED status	Meaning	Action of the user
	White continuous	The Smappee EV Ultra is available.	Connect your EV with the Smappee EV Ultra.
	Blue continuous	Your EV is connected with the Smappee EV Ultra, but is not yet charging.	<ul style="list-style-type: none"> <li>• If using an RFID, scan your charge card and wait until the LED turns flashing blue.</li> <li>• If using QR codes, scan the QR code and wait until the LED is green pulsing.</li> <li>• If no authorisation is required, wait until the LED becomes green pulsing.</li> </ul>
	Blue flashing	Your RFID card is being verified.	Wait until the LED is green pulsing.
	Green pulsing	The Smappee EV Ultra is charging your EV.	Your EV is being charged.
	Green continuous	The EV is now fully charged.	Disconnect the cable and put it back in its socket of the Smappee EV Ultra.
	Green blinking	Charing session is paused by Smappee Smart Charging	This is informative, no action required.
	Red continuous	The Smappee EV Ultra is unavailable.	Check the manual or contact your supplier for more info and further steps.
	Red flashing	Your charge card is not authorised.	Contact your charge card supplier.

## 9.5 Inverter fault codes

<b>Fault code</b>	<b>Analysis</b>	<b>Solution</b>
E02	Fan blocked	Remove the object that prevents the fan.
	Air duct blocked	Remove the object that blocks air duct or clear dust.
E03	AC input voltage is not in the normal range	Ensure AC input voltage is in the normal range
E05	Module positive and negative pole short circuit	Power off the charging module, check whether the positive and negative poles on the output circuit are short circuited, and reboot after confirming that there is no short circuit. If alarm persists, replace charging module.
E06	Module output voltage exceeds the set output overvoltage value	Power off the charging module, check whether the module output voltage has been changed, and check that the module output voltage is less than the set module output overvoltage value. And then, reboot after pulling out the charging module, if alarm persists, replace charging module.
E07	Address conflict	Reboot the charging station. If the error persists, contact support.
E09	The difference between the module current and average current is too large	Check charging module communication, check communication cable connection; If the communication is good and alarm persists, replace charging module.

# Declaration of conformity

**We,**

Smappee nv  
Evolis 104  
B-8530 Harelbeke  
Belgium

**following the provision of the following EC Directives:**

- 2014/35/EU The Low Voltage Directive
- 2014/30/EU The Electromagnetic Compatibility Directive
- 2011/65/EU RoHS Directive

**hereby declare that the product:**

EVBU-200-CCS3R, EVBU-80-CCS3R

**is in conformity with the applicable requirements of the following documents**

- \* Emissions:  
(EN61326-1 : 2013)  
Radiated Emission: EN 55011:2009 / EN 55032:2015 (Class B)  
Conducted Emission: EN 55011:2009 / EN 55032:2015 (Class B)  
Harmonic current Emission: EN 61000-3-2:2005 +A1:2008 + A2:2009  
Flicker: EN 61000-3-3:2008
- \* Immunity:  
(EN61326-1 : 2013)  
ESD : EN 61000-4-2:2008 / EN 61000-4-2 :2009  
Radiated immunity : EN 61000-4-3:2006 + A1:2007 + A2: 2010  
Power frequency magnetic field: EN 61000-4-8:2009  
Voltage dips/interruptions: EN 61000-4-11:2004  
Common Mode Immunity: EN 61000-4-6:2008 / EN 61000-4-6:2009  
Burst : EN 61000-4-4:2004 / EN 61000-4-4:2012  
Surge: EN 61000-4-5:2005 / EN 61000-4-5:2006
- \* Safety:  
Metering Function : IEC 61010-1 Ed 3.0 (2010-06) + A1:2016  
DC Charging equipment : IEC 61851-1 (2017), IEC 61851-21-2 (2018), IEC 61851-23 (2014), IEC 61851-24 (2014) , ISO 15118 / EN61558-1
- \* Other applicable standards and certifications: IEC 60364, IEC 62192-1, IEC 62192-2

Harelbeke, Belgium, May 11, 2021

Authorized signatory



Stefan Grosjean  
CEO

## Spare parts list

<b>Article no.</b>	<b>EAN</b>	<b>Description</b>
i1-GW-3	5425036931442	Smappee Connect
EV-RFID-READER	5425036933835	EV Line RFID Reader
i1-VAC-1	5425036931169	Smappee Power Box
AC-4P4GROUTER-1	5425036935594	Modular 4 Ports 4G LTE-router with DIN rail clip
EVBU-CNV40-1	5425036933774	EV Ultra 40 kW Air Cooling Highly protective charging module
EVU-IMD-1	5425036935600	EV Ultra IMD
EVBU-CBL-CSS250-3	5425036933842	EV Ultra 3 m Charging cable CCS 250 A
AC-IBC80-10	5425036935679	Smart Bus RJ10 Cable 80 cm - 10 pieces
i1-IAC-1	5425036931183	Smappee CT Hub
AC-RSCT-4CM	5425036934139	Rogowski coil 4 cm / 1.57 inches diameter
i1-GW-3	5425036931442	Smappee Connect

If you need another part than listed, please contact [info@smappee.com](mailto:info@smappee.com).