

Smappee EV Wall Lite Installation manual



Document accuracy

The specifications and other information in this document were verified to be accurate and complete at the time of its publication. Due to ongoing product improvement, this information is subject to change at any time without prior notice. For the latest information, see our online documentation: smappee.com/downloads

Table of contents

1	Introduction.....	4
2	Safety instructions.....	5
3	Overview of the EV Wall Lite.....	7
4	Preparing the installation.....	13
5	Installation and activation.....	17
	Annexes	25

1 Introduction

Thank you for purchasing this EV Wall charging station for electric vehicles, the smartest charging station.

This installation manual tells you how to install the EV Wall Lite. We recommend that you read the contents of this manual carefully, to ensure a safe and proper installation and enable to use all the advanced features of this product to the full.

Intended use

This charging station is designed for charging electric vehicles using a compatible Type 2 charging cable connected to the socket outlet. The use of intermediate adapters or extension cables is not permitted.

Use for any other purpose than EV charging as defined in the IEC 61851-series is not and constitutes misuse of the charging station. Only qualified, trained and authorised persons are allowed to install, maintain and/or repair the charging station and make sure that the technical specifications and installation requirements are met. Incorrect installation and testing of the charging station could potentially damage either the vehicle's battery or the device. Any resulting damage is excluded from the warranty of the device. Any modification that is not in writing confirmed by Smappee will void the warranty. For more information, refer to smappee.com/legal-documents.

Support

Only qualified electricians or equivalent may install the charging station. If you have any questions, please contact your service partner.

Please have the following information ready to hand to speed up the process: Article number and serial number which you can find on the identification label of the charging station.





Should your local distributor be unable to help you, or you have a suggestion for us, you can contact Smappee at: support@smappee.com.

Smappee NV
Evolis 104
8530 Harelbeke
Belgium

2 Safety instructions

2.1 Safety warnings and precautions

	<p>WARNING</p> <p>Carrying out activities on this charging station without the relevant knowledge and qualifications can lead to serious accidents and death. Only carry out tasks for which you are qualified and have been fully instructed.</p> <p>Only certified electricians may carry out the installation, which must be in accordance with the national safety regulations.</p> <p>Fully read and follow the safety instructions below before you install, service or use your EV Wall. Incorrect installation, repairs or modifications can result in danger to the user and may void the warranty and liability.</p>
	<p>CAUTION</p> <p>Risk of electric shock.</p> <p>Refer to the accompanying documentation whenever you see this symbol.</p>

Please observe the following safety precautions to avoid potential electric shock, fire, or personal injury:

- Use the correct tools and provide sufficient material resources and protection measures.
- The charging station is, when installed correctly, intended to be used by untrained individuals to exclusively charge their electric vehicle.
- Do not allow children to operate a charging station.
- When a charging station is in use, adult supervision of any children present is required.
- Switch off electrical power supply to your charging station before installation or maintenance work.
- Do not use the charging station if it is damaged or defective.
- Do not immerse the charging station in water or any other liquids.
- Do not expose the charging station to heat, flame or extreme cold.
- Do not attempt to open, repair, or service any parts. Contact Smappee or your service partner for further information.
- Only use the charging station under the specified operating conditions.
- While charging the charging cable must be completely unwound and connected to the electric car without overlapping loops. This to avoid the risk of overheating the charging cable.
- After charging store the charging cable properly so it does not present a tripping hazard. Make sure the charging cable cannot become damaged (kinked, compressed or driven over).
- Do not place any objects on the charging station.

2.2 Maintenance

- Observe the maintenance schedule (page 32).
- Clean the outside only with a dry, clean cloth.
- Do not use abrasive agents or solvents.
- May not be carried out during rain or if air humidity exceeds 95 %.

2.3 Transport and storage

- Disconnect electrical power supply before removing the charging station for storage or relocation.
- Only transport and store the charging station in its original packaging. No liability for damage incurred will be accepted if the charging station is transported in non-standard packaging.
- Store the charging station in a dry environment within the temperature range specified in the technical specifications.

3 Overview of the EV Wall Lite

3.1 Models

Article number	EAN	Description
EVWL-332-BR-E-W	5425036933989	EV Wall Lite 3-Phase 22 kW Socket
EVWL-332-BSR-E-W	5425036933996	EV Wall Lite 3-Phase 22 kW Socket with shutter

3.2 What's in the box

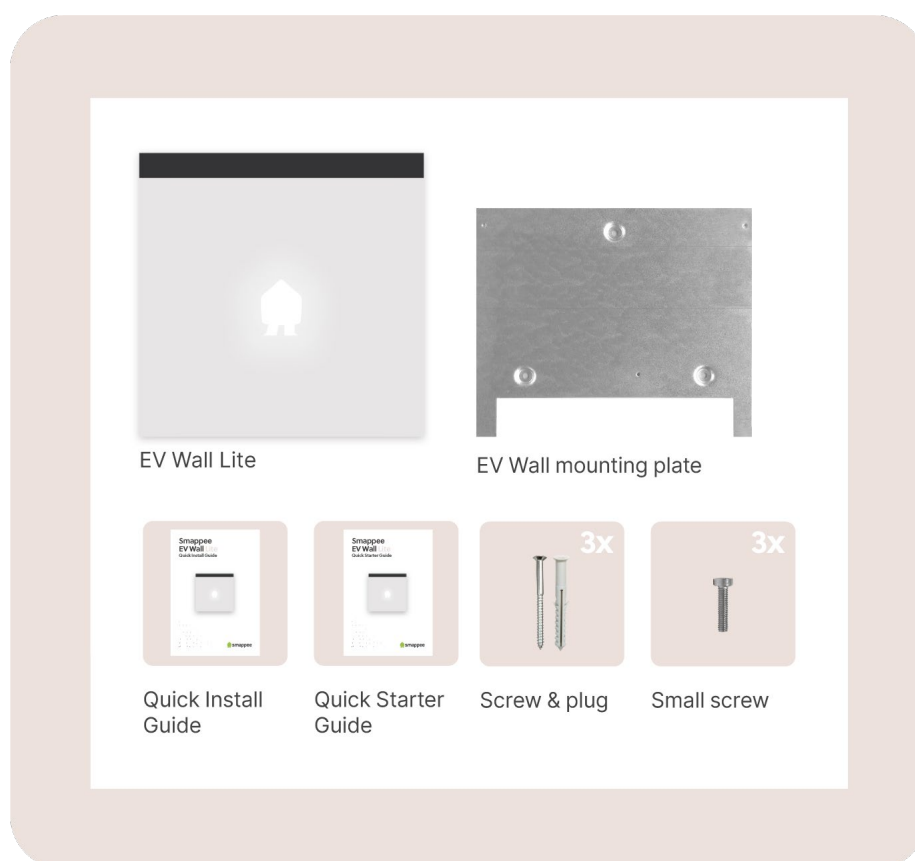

Image 1: What's in the box for the EV Wall Lite

EV Wall box

Quantity	Description
1	Snapppee EV Wall
1	Wall mounting plate
1	Quick install guide
1	Quick starter guide with Smart Charge Card and QR code for Scan and charge
3	Screw and plug (Ø 6 mm x 50 mm)
3	Small screw (M4 x 6 mm)

3.3 Directional determination

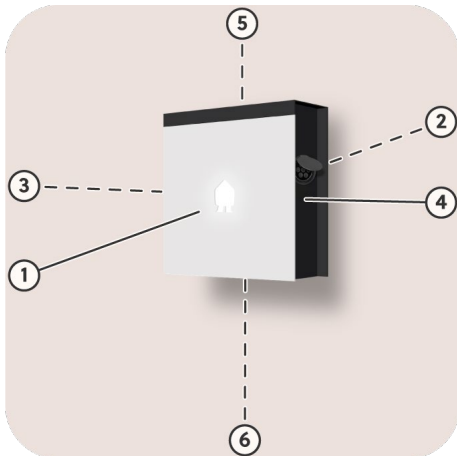

Image 2: Directional determination

Id	Description
1	Front
2	Rear
3	Left
4	Right
5	Top
6	Bottom

3.4 Identification label of the EV Wall

Position of the identification label of the EV Wall

The identification label is on the bottom of the charging station.



Image 3: Position of the identification label

Identification label of the EV Wall



Image 4: Identification label

No.	Description
1	Manufacturer
2	Article number
3	Electrical rating
4	Operating temperature
5	Manufacturing date
6	QR code to scan during configuration of the charging station
7	Ingress protection rating
8	CE
9	EAN-code
10	Serial number
11	Waste disposal symbol

3.5 Technical specifications

Feature	Description
Physical properties	
Dimensions	300 mm x 300 mm x 110 mm
Weight (excluding packaging)	7.3 kg
Socket	All variants manufactured as of January 31, 2025, have a Type 2 socket with shutter.
Charging cable	N/A
Supply line connection	Terminal block, flexible conductors up to 6 mm ² or solid conductors up to 10 mm ²
Stationary / moveable	Fixed installation
External design	Enclosed assembly
Mounting method	Wall
Technical features	
Maximum nominal power	Single-phase connection: 7.4 kVA Three-phase connection: 22 kVA
Charge mode	Mode 3 (IEC 61851)
Connection case	Case A and B (Socket) (IEC 61851)
Metering	kWh meter compliant with IEC 62053-21 and accuracy of 1%
Integrated Residual Current Protection	6 mA DC RCM ¹
Required external circuit breaker	1 x 2P (single-phase), 1 x 3P (three-phase) or 1 x 4P (three-phase with neutral) breaker of maximum 40 A, type B or C
Supported power systems	TN-C, TN-C-S, TT, IT ²
Grounding	TN system: PE wire TT system: Independently installed ground electrode < 100 Ohm spreading resistance IT system: connected to a shared reference (common earth) with other metal parts
Rated voltage (U _N)	230/400 VAC
Rated insulation voltage (U _i) of a circuit	500 V
Rated impulse withstand voltage (U _{imp})	4 kV
Rated frequency (f _N)	50 Hz / 60 Hz
Rated current (I _{na})	32 A
Rated current (I _{nc}) of a circuit	32 A

¹ The variants EVWL-332-BR-E-W and EVWL-332-BSR-E-W have only a 6 mA DC residual current monitor. They need a 30 mA residual current device Type A or B (according to local regulations).

² Caution: not all vehicles support the IT system. For 3 x 230 V charging, a voltage transformer might be necessary.

Feature	Description
Rated peak withstand current (I _{pk})	6 kA
Rated conditional short-circuit current (I _{cc})	6 kA
EMC classification	Class B
Connection method	AC, permanently connected
Interfaces & Connectivity	
Information status	RGB LED
Session activation	Plug and charge, Swipe RFID
Connectivity	Ethernet 100BASE-T, Wi-Fi 2.4 GHz
Communication protocol	OCPP 1.6 JSON, ready for update to OCPP 2.0
Certifications and Standards	
Product certification	CE
Standards	IEC 61851-1 (2017)
Environment	
Enclosure material	Magnelis (housing), aluminium (front plate)
Enclosure standard colours	RAL 9016 (star white), RAL 7021 (black grey)
Protection degree	IP 54
Mechanical impact protection	IK10
Pollution degree	3
Electrical safety class	I
Stand-by use	LED brightness 0%: 2 W LED brightness 100%: 5 W
Environmental conditions	Indoor and outdoor use
Operating temperature	-25 °C to 40 °C
Storage temperature	-25 °C to 60 °C
Relative humidity	0 % to 95 %, non-condensing
Maximum installation altitude	0 – 2000 m
Access	Locations with restricted and non-restricted access



NOTE

- The operating temperature assumes the ambient temperature of a product delivered in the default enclosure colour RAL 9016 (star white). Direct exposure to sunlight may have an adverse effect on the temperature range.
- If the product is exposed to lower or higher ambient temperatures, continuous operation cannot be guaranteed. If temperatures exceed the maximum values, the charging station will automatically decrease the charging current to decrease the internal temperature of the charging station. This stabilises the internal temperature and makes it less likely that a charging session will be unexpectedly paused.
- If the product is directly exposed to sunlight, the automated temperature management may automatically start below the maximum ambient temperature. Therefore, wherever possible, avoid exposing the charging station to direct sunlight.
- Where products are exposed to the elements of nature, the enclosure can be subject to gradual aging of the material, which can result in product discolouration over time. Therefore, wherever possible, place the product in a sheltered place to optimise the life of the materials.

4 Preparing the installation

The first step is to prepare the physical installation of the EV Wall Lite as described in this chapter.

4.1 Installation prerequisites

- Obtain all necessary permits from the relevant local authorities.
- Local regulations may be applicable and can vary depending upon the region or country.
- Make sure that there is sufficient space around the charging station as specified in the IEC 60204-1 standard.

	<p>NOTE</p> <p>When positioning the EV Wall, take into account that the power supply cable and network cable are entering the housing at the bottom through cable glands. The central M32 cable gland is for the power supply, the M20 cable gland for a network cable.</p>
---	--

- Make sure that the installation area of the charging station is adequate for usability and ventilation purposes.
- Refer to local wiring regulations to select the conductor sizes and use only copper conductors.
- Calculate the existing electrical load to find the maximum operating current for the charging station installation.
- The appropriate wire gauge of the supply cable depends on the power rating and distance between the meter cabinet and the charging station. The voltage drop must not exceed 5 %. It is advisable to have a maximum voltage drop of 3 %.
- The power supply connection must be protected against short-circuiting and over-current with an individual circuit breaker. This circuit breaker must be 2-pole (for single-phase), 3-pole (three-phase without neutral) or 4-pole (three-phase with neutral), curve B or C, and have a current rating of maximum 40 A (or otherwise in compliance with local standards and regulations).

	<p>NOTE</p> <p>Some EVs are not compatible with a 3 x 230 V grid due to a built-in security in the EV. Contact your EV manufacturer for more information. If your EV is not compatible with this grid topology, or if you would like to achieve higher charging power than what is possible on a delta grid topology, you can install a transformer that converts the 3 x 230 V topology to a standard 3 x 400 V + N topology.</p>
---	---

- An RCD of type A or B (according to local regulations) with rated residual operating current of 30 mA must also be installed.

- Route the power supply cable and a network cable to the position where the charging station will be installed.



NOTE

Make sure that there is at least 30 cm power supply and 30 cm network cable length available at the location of the EV Wall to be able to connect it easily.

- Use the supplied wall mounting plate (page 16) to attach the EV Wall.

4.2 Tools (not included)

- Torque wrench with extension bar and socket (inner hex 2.5 and 4 mm and screw width 8 mm)
- Multimeter and earth ground meter
- Wire stripper and cutter
- Needle-nose pliers
- Ferrules crimper (only for stranded power supply cables)
- RJ45 crimping tool
- Rock drill diameter 8 mm (only for floorplate)
- Hammer
- Screwdrivers

4.3 Supplies (not included)

- Power supply cable
- Circuit breaker for power supply
- Circuit breaker for Power Box (only for 3 x 230 V with transformer)
- Wi-Fi extender if the signal is weak or absent
- Network cable and RJ45 connectors, minimum Cat 5 depending on the environment, if using wired internet connection
- Smappee Bus cable and RJ10 connectors, if using alternative connection to the internet
- Ferrules, when using stranded power supply cables

4.4 Prepare the EV Wall

Context

The EV Wall mounting plate is in the same box as the EV Wall, together with the supplies.

Instructions

Proceed as follows.

1. Remove the cardboard packaging.
Keep in mind to store the cardboard, as this can be used to safely store the frontplate while installing the EV Wall.
2. Unscrew the two inner nuts that hold the front plate.
3. Make sure to keep the nuts for later use.
4. Lift the front plate.

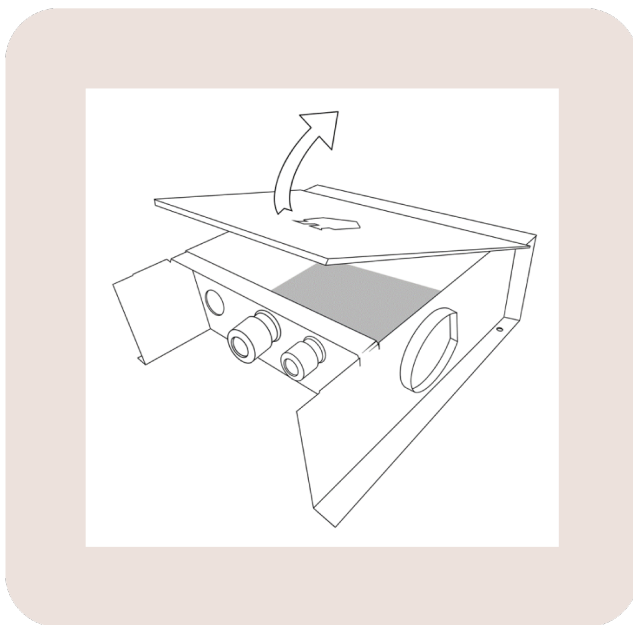

Image 5: View on the front plate

5. Disconnect the black cable to the PCB from the front plate.
6. Remove the front plate.
Put the plate in a safe location where it cannot be scratched or damaged.
Put the nuts on the threaded rods to avoid losing them.

As a result, the EV Wall is prepared for the next steps.

4.5 Install the EV Wall mounting plate

Context

The EV Wall mounting plate lets you smoothly attach the charging station to a wall.

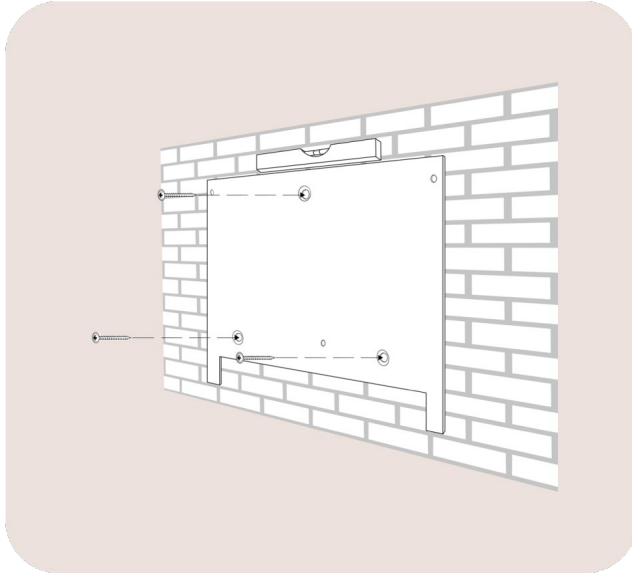

Image 6: View on the EV Wall mounting plate

Instructions

Proceed as follows.

1. Put the mounting plate on the position where the EV Wall will come.
Make sure the mounting plate is positioned with the 2 insert holes on the bottom.
Make sure the mounting plate is level.
2. Use the mounting plate to mark the position of the screws on the wall.
3. Drill three holes of 10 mm diameter through the slots to a depth of 50 mm.
4. Insert the supplied wall plugs into the holes.
5. Attach the mounting plate, with the 3 bulges facing the wall, with the supplied screws.

5 Installation and activation



CAUTION

The installation must be carried out by a qualified professional who has read this manual and works in compliance with local and national standards. Neglecting this may lead to severe injuries or hazardous situations while working with electricity.



CAUTION

The electric system must be entirely disconnected from every power source prior to performing installation or maintenance work. Make sure it is not possible to connect the electric current during installation. Put up caution tape and warning signs to mark the work areas. Make sure no unauthorised people can enter the work areas.



CAUTION

The charging station contains electric components that may still contain electrical charge after being disconnected. Wait at least 10 seconds after disconnection before commencing work.



CAUTION

Adaptors or conversion adaptors and cord extension sets are not allowed to be used.

This procedure describes the required steps for the physical installation of the EV Wall Lite.

1. Attach the EV Wall to the mounting plate (page 18)
2. Connect the power supply of the EV Wall (page 19)
3. Connect the EV Wall to the internet (page 20)
4. Install the front plate (page 22)

After the physical installation, the configuration can be done. For more information, refer to:

5. Configure the EV Wall with the Smappee App (page 23)
6. Complete the installation of the EV Wall (page 24)

5.1 Attach the EV Wall to the mounting plate

Context

The EV Wall mounting plate lets you smoothly attach the charging station to a wall.

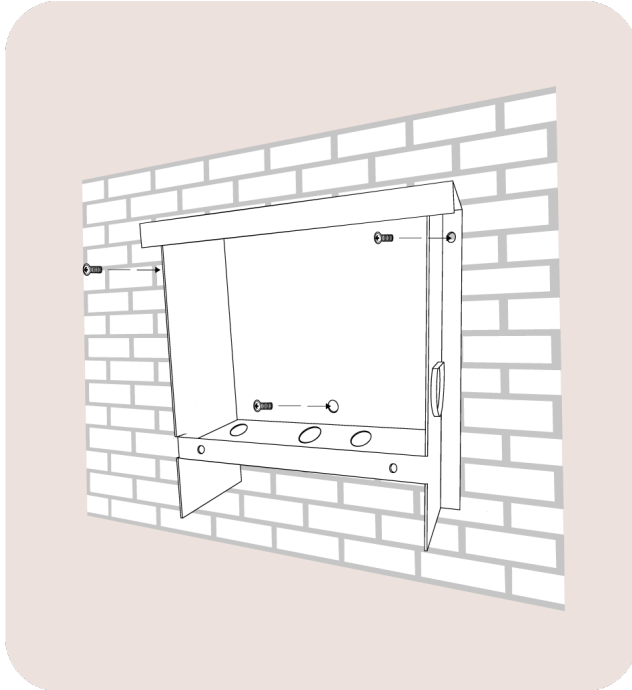

Image 7: View on the EV Wall

Instructions

Proceed as follows.

1. Position the EV Wall in front of the mounting plate.
2. Attach the EV Wall to the mounting plate.
Use the three M4 x 6 mm hex screws.

5.2 Connect the power supply of the EV Wall

Context

Each EV Wall has a Solid Core 3-Phase CT that measures the power supplied to the charging station. No other components must be installed to measure the charging station consumption.

Each EV Wall must have a dedicated own circuit breaker and residual current device. For more information, refer to Installation prerequisites (page 13). The electronics in the EV Wall Lite has changed, as you can see in the following images:

- Serial number starting with 6222

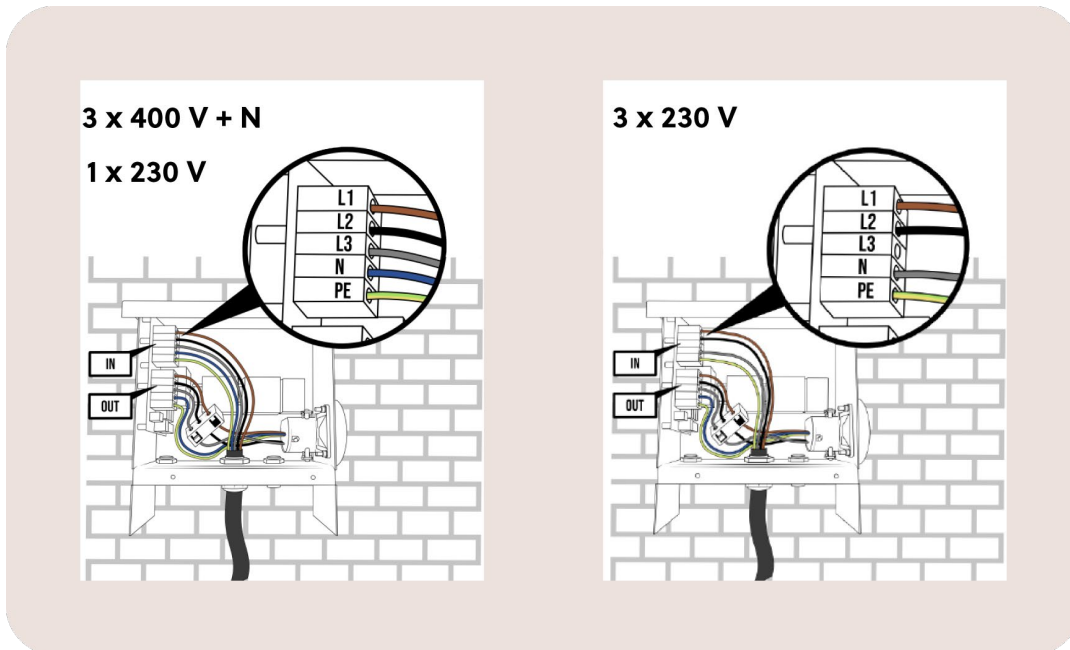

Image 8: View on the power supply connection for EV Wall Lite with the serial number starting with 6222

- Serial number starting with 6202

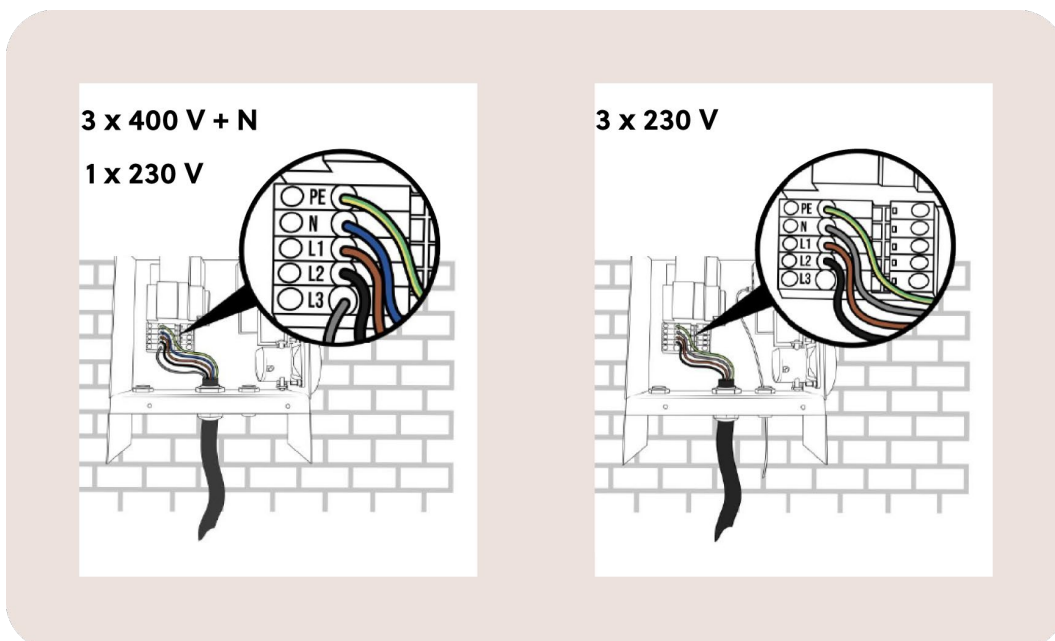



Image 9: View on the power supply connection for EV Wall Lite with the serial number starting with 6202

Instructions

1. Guide the power supply cable through the cable gland in the middle of the EV Wall.
Tighten the cable gland.
2. Cut the power supply cable to the sufficient length.
For stranded wires, add a wire end ferrule to each conductor.
3. Connect the power supply wires as follows:
 - The left Image 8 and Image 9 show the connection points for a 3 x 400 V + N and a 1 x 230 V power supply.

	NOTE <ul style="list-style-type: none">• PE = green/yellow conductor• N = blue neutral conductor• L1 = brown phase 1-conductor• L2 = black phase 2-conductor, not applicable for 1 x 230 V• L3 = grey phase 3-conductor, not applicable for 1 x 230 V
---	--

- The right Image 8 and Image 9 show the connection points for 3 x 230 V power supply.

	NOTE <ul style="list-style-type: none">• For a 3 x 230 V without a transformer, there is no neutral (N) wire. The images show that the grey L3 wire comes in the connection point for the neutral (N).• For a 3 x 230 V with a transformer, the neutral wire comes from the transformer. Connect the power supply wires as in the left image.
---	---

As a result, the EV Wall is almost ready for power.

5.3 Connect the EV Wall to the internet

Context

	CAUTION <p>Risk of electric shock.</p> <p>Make sure no tools are in the charging station and people stand free from the charging station.</p>
---	--

	NOTE <p>If you are using Wi-Fi for internet connectivity and the signal strength is weak, it is possible to move the Smappee Connect outside of the metal EV Wall to improve the signal strength. When the owner is concerned about the security of a network cable that goes out the building, there is a possibility to have a Smappee Bus cable that goes out the building and the Connect can be moved outside the EV Wall. For more information, refer to Alternative connection to the internet (page 26).</p> <p>You may prefer to add a Wi-Fi extender for optimal EV Wall performance.</p>
---	--

Instructions

Proceed as follows.

1. Guide the network cable through the right cable gland at the bottom of the EV Wall.
2. Cut the network cable to the necessary length.
3. Attach the RJ45 connector (not supplied).
4. Put the connector in the RJ45 port of the Smappee Connect.

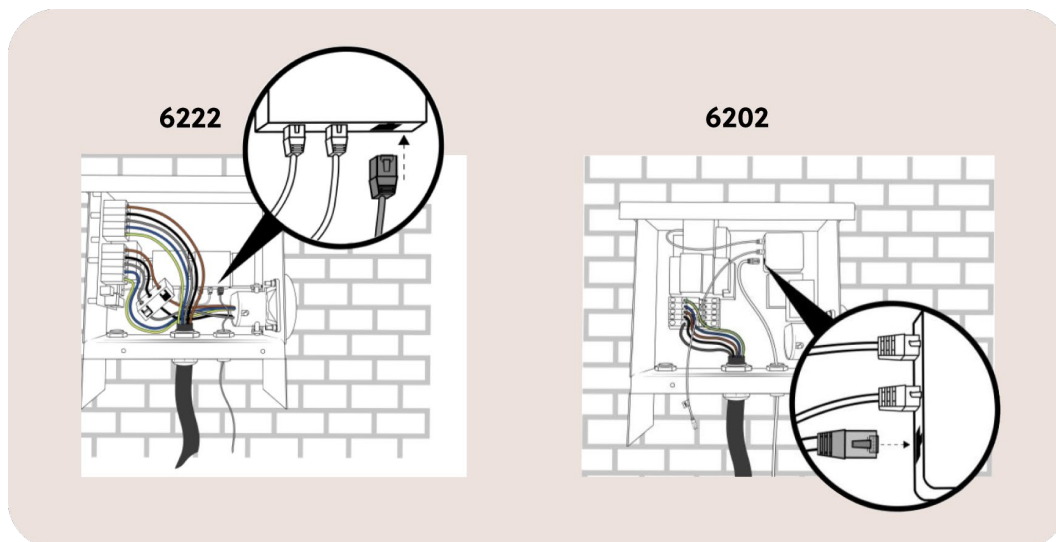

Image 10: View on the RJ45 port for EV Wall Lite with the serial number starting with 6222 and 6202

5. Tighten the cable gland.
6. Start the power supply to the EV Wall.
Make sure the circuit breaker and the RCD are set to the on position.
7. Check the status of the components after approximately 30 seconds.

Description	More information
1 x Smappee Connect	LED is lighting up
1 x Power Box	LED is flashing once every 3 seconds.
1 x Solid Core 3-Phase CT	

For more information, refer to Colour code explanation (page 29).

8. Stop the power supply to the EV Wall.

5.4 Install the front plate

Context

The front plate has a PCB with RFID reader and LED for the Smappee Avatar.

Instructions

1. Remove the nuts from the threaded rods of the front plate.
2. Connect the black cable to the PCB attached to the front plate.

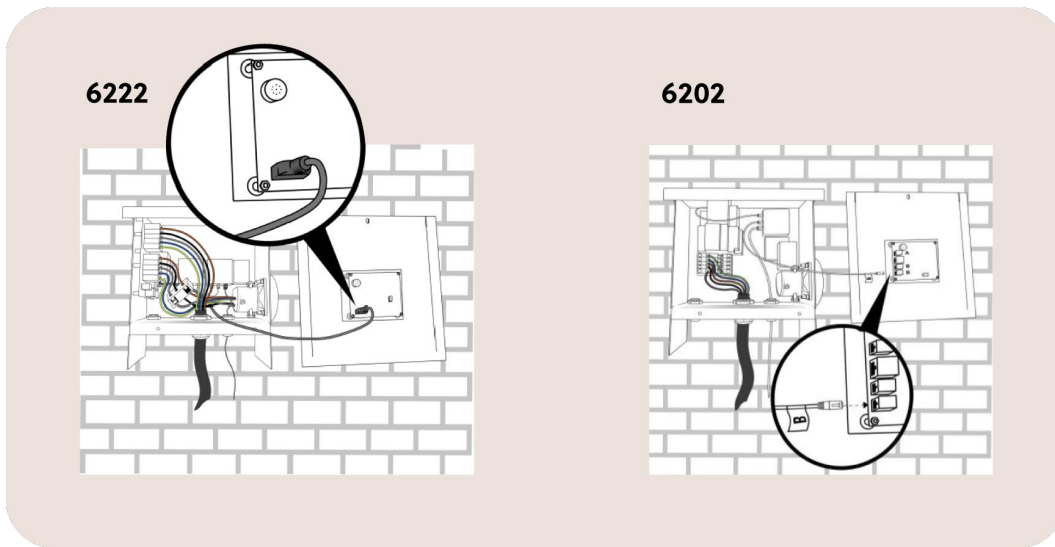

Image 11: View on the 12-pin cable (6222) and the RJ10 cable on the B-port (6202) on the PCB

- For EV Wall Lite with the serial number starting with 6222 this is a 12-pin cable
- For EV Wall Lite with the serial number serial number 6202 this is a bus cable, to be put in a B-port

Make sure not to use the A-port on the PCB.

Make sure the cable is at the other side connected to a B-port on the Smappee Connect.

3. Put the front plate back.
4. Put the nuts on the threaded rods to avoid losing them.

As a result, the EV Wall is ready to be configured with the Smappee App.

5.5 Configure the EV Wall with the Smappee App

Prerequisites

This procedure is done with the Smappee App. You can download this mobile app from the Apple App Store for iOS or the Google Play store for Android phones.



Image 12: Download the Smappee App

Instructions

Proceed as follows:

1. Open the Smappee App.
Login to the Smappee App with your partner user account.

	<p>NOTE</p> <p>If you have not yet a partner user account, go to https://forms.office.com/e/zxWJq7QqUc.</p>
--	--

2. Tap the **House** button.
3. Tap the **+** button.
4. Tap the **I want to install a Smappee charging station** button.
5. Follow the steps shown in the Smappee App.

	<p>NOTE</p> <p>If the EV will not charge on a 3 x 230 V without transformer, you can try to disconnect the L2 cable going to the socket.</p> <p>Do not disconnect the L2 of the power supply cable.</p>
---	--

Post-requisites

The settings of your charging station can be adjusted in the Smappee App or the Smappee Dashboard.

- Name
- LED brightness
- Maximum current and thus the charging speed

5.6 Complete the installation of the EV Wall

Instructions

Proceed as follows.

1. Put the M4 nuts on the threaded rods and tighten them.

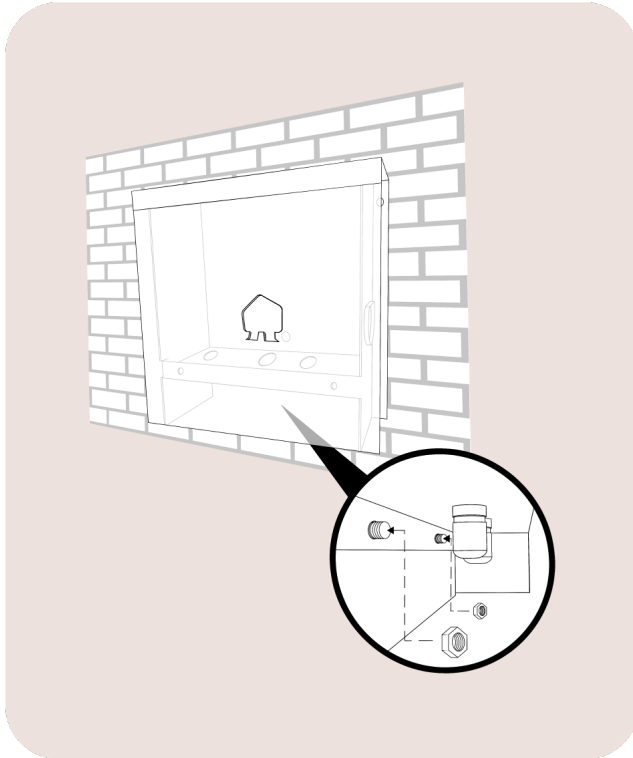

Image 13: View on the inner nuts

As a result, the EV Wall is ready for use. For more information, refer to the annex Status of the charging station (page 31).

Annexes

Declaration of conformity

Declaration of conformity

We,
Smappee nv
Evolis 104
B-8530 Harelbeke, Belgium

following the provision of the following EC Directives:

- 2014/35/EU The Low Voltage Directive
- 2014/30/EU The Electromagnetic Compatibility Directive
- 2011/65/EU RoHS Directive

hereby declare that the product:

EVWL-332-BR-E-W, EVWL-332-BSR-E-W

is in conformity with the applicable requirements of the following documents

- Emissions:
(EN61326-1 : 2013)
Radiated Emission: EN 55011:2009 / EN 55032:2015 (Class B)
Conducted Emission: EN 55011:2009 / EN 55032:2015 (Class B)
Harmonic current Emission: EN 61000-3-2:2005 + A1:2008 + A2:2009
Flicker: EN 61000-3-3:2008
- Immunity:
(EN61326-1 : 2013)
ESD : EN 61000-4-2:2008 / EN 61000-4-2 :2009
Radiated immunity : EN 61000-4-3:2006 + A1:2007 + A2: 2010
Power frequency magnetic field: EN 61000-4-8:2009
Voltage dips/interruptions: EN 61000-4-11:2004
Common Mode Immunity: EN 61000-4-6:2008 / EN 61000-4-6:2009
Burst : EN 61000-4-4:2004 / EN 61000-4-4:2012
Surge: EN 61000-4-5:2005 / EN 61000-4-5:2006
- Safety:
Metering Function : IEC 61010-1 Ed 3.0 (2010-06) + A1:2016
AC Charging equipment : IEC 61851-1 (2017) / EN61558-1
- Other applicable standards and certifications: IEC 60364, IEC 62192-1, IEC 62192-2

Harelbeke, Belgium, January 13, 2023

Authorized signatory



CEO Smappee



Alternative connection to the internet

Context



NOTE

This section is only applicable to the EV Wall Lite with a serial number starting with 6222.



CAUTION

The electric system must be entirely disconnected from every power source prior to performing installation or maintenance work. Make sure it is not possible to connect the electric current during installation. Put up caution tape and warning signs to mark the work areas. Make sure no unauthorised people can enter the work areas.

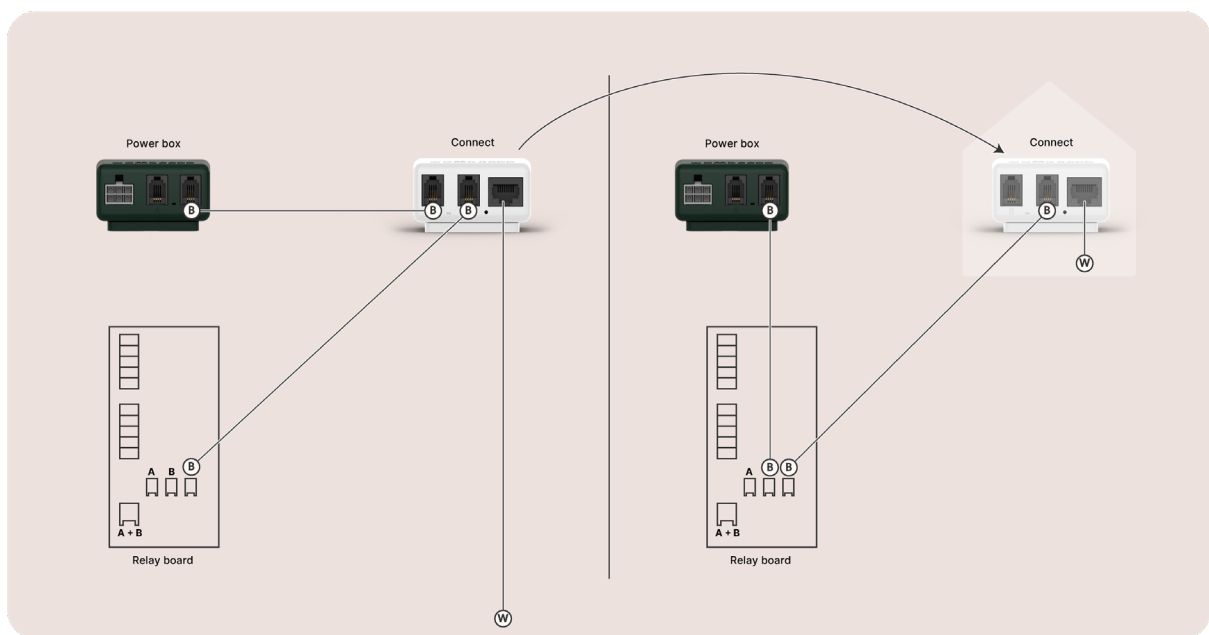

Image 14: Schematic view on normal connection and alternative connection

Instructions

Proceed as follows to move the Smappee Connect inside the building.

1. Disconnect the Smappee Bus cables between the Power Box, the relay board and the Connect.
2. Make a connection with a Smappee Bus cable between:
 - The B-port on the Power Box
 - One of the B-ports on the relay boardMake sure not to use the A-port on the relay board.
3. Make a connection with a custom length RJ10 cable between:
 - One of the B-ports on the relay board
 - One of the B-ports on the ConnectMake sure not to use the A-port on the relay board.

The RJ10 cable (not included) goes through the right cable gland of the EV Wall to the Connect in the building. For more information, refer to Necessary tools for alternative connection (page 28). The Connect should be attached to a wall mounting plate (not included).

4. If you want to connect the EV Wall Lite via a wired internet connection, make connect a network cable to the RJ45 port of the Connect.

As a result, you can continue the installation as of Start the power supply to the EV Wall. Check the status of the components. Check the status of the components page 21.

Necessary tools for alternative connection

You can order the following items.

Description	Article number
Wall mounting plate kit (8 pieces)	AC-IMPW-8
DIN mounting plate kit (4 pieces)	AC-IMPD-4
Smappee Bus cable – 15.75 inches (40 cm)	AC-IBC40
Smappee Bus cable – 59 inches (150 cm)	AC-IBC150
Smappee Bus cable set – 109 yards (100 m) and 50 RJ10 connectors	AC-IBCS-100m

If the Smappee Bus cable is not sufficient long, you can use a custom RJ10 cable with the following specifications:

- A cable containing 2 unshielded twisted pairs (e.g. Cat 5 UTP cable). Shielded cable may also be used (e.g. Cat 6 UTP cable).
- No longer than 500 meters
- Pins 1 and 4 and pins 2 and 3 must be twisted pairs.



Image 15: Twisted pairs

- Straight connection: pin 1 to 1, etc.
- Characteristic impedance of 100 ohm.

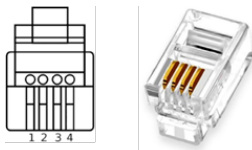

Image 16: Connector

- AWM style 2835: 60°/30 V – 24 AWG.

Colour code explanation

Status of the Smappee Connect

This status is relevant during the configuration and use of the charging station.

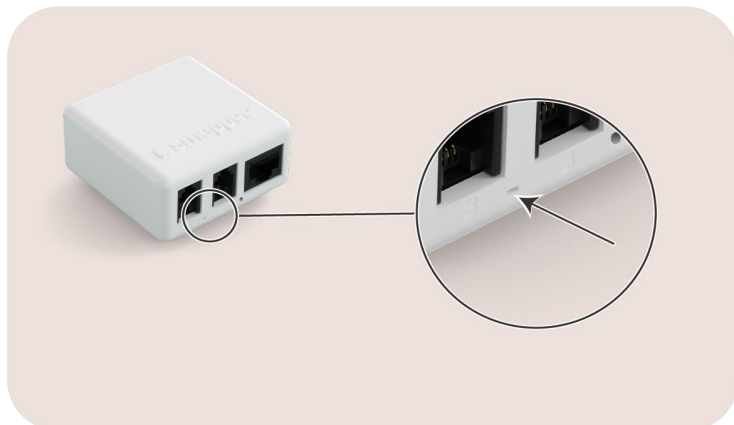







Image 17: Position of the LED on the Smappee Connect

Colour	Status	Meaning	More information
	Blue continuous	Starting up	The Connect is starting up. If this takes more than 30 seconds, please contact support.
	Blue flashing	Ready for connecting	The Connect is ready to be connected to the network.
	Green continuous	Connecting	The Connect is connecting to the internet and must become <i>Green breathing</i> . If this takes more than 2 minutes, please contact support.
	Green breathing	All good	The Connect operates correctly.
	Red flashing	No connection	The Connect has no connection to the internet during start-up. Find the cause of the connection issue or contact support.

Smappee Power Box

LED status	Meaning
Status LED is flashing once every 3 seconds.	The Power Box is powered on and operating correctly.
Status LED is flashing once every 1 second.	Smappee Bus B error.

Smappee Solid Core 3-Phase CT

LED status	Meaning
LED at input A, B, C or D 3 pulses per second, on any of the inputs A, B, C, D.	Indication of the selected input during configuration.
LED at input A Short pulse every 3 seconds.	The Solid Core 3-Phase CT is powered on and operating correctly.
LED at input A One pulse every second.	Communication error.
LED at input A 2 pulses per second.	Configuration problem.

Status of the charging station

This status is relevant during the use of the charging station.

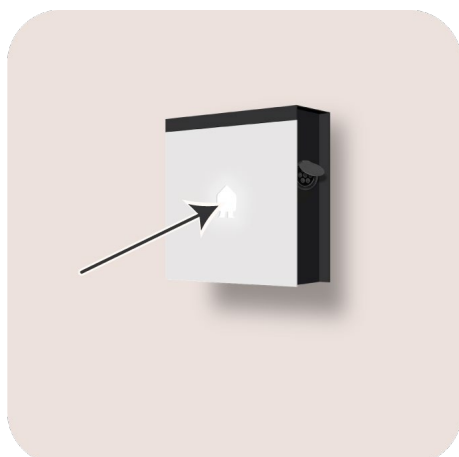









Image 18: Position of the RFID reader with LED on the EV Wall

Colour	Status	Meaning	Action of the user
	Red continuous	Charging station is unavailable.	Something is wrong or the charging station has been disabled. Enable the charging station with the Smappee App or contact your installer.
	White continuous	Charging station is available.	Connect your electric vehicle (EV) with the charging station.
	Blue continuous	EV is connected to the charging station but is not yet charging.	If no authorization is necessary, wait 3 seconds until you hear a sound and the LED is green. If the LED stays blue, do one of the following: <ul style="list-style-type: none"> • Swipe your RFID tag (charge card, RFID key, ...) along the blue indicator of the charging station. • Scan the QR code, if applicable
	Blue flashing	Authorization is being verified.	Wait 15 seconds until the authorization is finished and you hear a sound. The LED is red if charging has not started or green if charging has started.
	Red flashing	RFID tag is not authorized.	Contact the supplier of the RFID tag.
	Green breathing	EV is being charged.	Your EV is being charged.
	Green flashing	Charging session is waiting to charge or paused by an overload	This is informative, no action required.
	Green continuous	EV is charged	Disconnect the charging cable and put it safely back in the storage place.

Maintenance schedule

To ensure safe and reliable operation, periodic maintenance and inspections are recommended. The frequency depends on usage and environmental conditions.



WARNING

Before starting maintenance activities, consider all safety precautions as listed in Safety instructions (page 5).



NOTE

For publicly accessible charging stations, periodic inspections may be required by local regulations. Check applicable guidelines for compliance.

Task	More information
Visual inspection of the charging station	Check for visible damage or wear. If necessary, consult an installer for assessment or replacement.
Cleaning	Cleaning is optional and does not affect the operation of the charging station. For aesthetic reasons, you may wipe the unit with a dry, clean cloth. Do not use water jets, solvents, or abrasive materials.

Spare parts list

Article no.	EAN	Description
i1-GW-3	5425036931442	Smappee Connect
EV-RFID-READER	5425036933835	EV Line RFID Reader
i1-VAC-1	5425036931169	Smappee Power Box
EV-PCB-RELAYBOARD-2x2P-1	5425036935556	EV Line Relayboard 2 x 2P
EVW-CBL-HOLDER-4	5425036934191	EV Wall Cable holder - 4 pieces
AC-IBC40-10	5425036935648	Smart Bus RJ10 Cable 40 cm - 10 pieces
EVW-CBL-T2-132-8-NCH	5425036933613	EV Wall 1-Phase 32A Type 2 open-ended charging cable 8m
EVW-CBL-T2-132-8	5425036932623	EV Wall 1-Phase 32A Type 2 open-ended charging cable 8m with cable holder
EVW-CBL-T2-332-8-NCH	5425036933620	EV Wall 3-phase 32A Type 2 open-ended charging cable 8m
EVW-CBL-T2-332-8	5425036932470	EV Wall 3-phase 32A Type 2 open-ended charging cable 8m with cable holder
EVW-COVER-B	5425036933606	EV Wall Cover Black
EVW-COVER-W	5425036933538	EV Wall Cover White

If you need another part than listed, please contact info@smappee.com.